

# XTP601 Series

## Oxygen Analyzer for Safe or Hazardous Areas

A robust, linear and stable oxygen analyzer for measurements in gases such as hydrogen, nitrogen or CO<sub>2</sub>. The sensor is housed in a rugged casing, making it suitable for a wide range of applications. When the flame arrestors are fitted, the analyzer becomes explosion-proof and suitable for hazardous areas.



**Ti** Techingenium

Distribuidores autorizados para Uruguay  
 Venta - Ingeniería - Instalación - Mantenimiento  
 Dirección Jaime Zudáñez 2516  
 Teléfono: 2711 09 86  
 Montevideo Uruguay  
 Mail: info@techingenium.com.uy  
 www.techingenium.com.uy

### Highlights

- Compact and rugged design with an EExd enclosure and isolated 4-20 mA output
- ATEX, IECEx & cCSA<sub>US</sub> Hazardous Area certified
- Touch-screen display allows calibration or adjustment without the need for a hot works permit
- Excellent accuracy of better than 1% FS
- Zero span stability better than 0.25% of span per month
- Increased protection against contamination due to cell design
- Low cost of ownership due to minimal maintenance
- Ranges available: 0-1% up to 0-25% & 80 or 90-100%

### Applications

- Oxygen measurement at inlet of compressors in steel or gas industries to monitor safety
- Biogas, waste, landfill and digester plants
- Inert gas for pharmaceutical or chemical industries
- Monitoring inert blanketing gases in oil tankers
- Furnace gas control in steel industry
- Hydrogen coolant in electricity turbines
- Catalyst regeneration
- And many more...

# Michell XTP601 Oxygen Analyzer for Safe or Hazardous Areas

When a process oxygen application demands high accuracy and stability, along with low maintenance cost, paramagnetic oxygen technology is usually preferred. If, in addition, the application calls for a rugged and reliable, corrosion resistant analyzer, the thermo-paramagnetic principle of Michell's new XTP601 series makes it the instrument of choice.

The XTP601 series oxygen analyzers from Michell Instruments are designed to measure the percentage of oxygen in process gases. Using thermo-paramagnetic technology, the sensor is reliable and highly stable. The XTP601 is housed in an explosion-proof case and is rated ATEX Zone 1 for use in hazardous areas. For installation in non-hazardous areas a general purpose version is available.

## Features

### Excellent accuracy

Oxygen measurements are highly susceptible to pressure variations because they are generally based on the partial pressure of oxygen. For a non-corrected analyzer, a 1% change in atmospheric pressure will result in a 1% change in the reading. The XTP601 has barometric pressure compensation fitted as standard and is ranged specifically to customers' needs to offer the best accuracy where it matters. For instance, in a 0-1% range the XTP601 is accurate to  $\pm 0.02\% \text{ O}_2$ .

### Higher sensor stability reduces calibration costs

The sensor in Michell's XTP601 analyzer largely eliminates thermistor drift associated with other comparable devices, improving the stability of the measurement. This allows longer calibration intervals and reduces both labor and consumable costs.

### Reliable long-term performance

In some installations, such as offshore or on board oil tankers, the movement and vibrations present could affect the moving parts of other kinds of sensors. The thermo-paramagnetic sensor has no moving parts making it ideal for these applications.

### Non-depleting technology

The sensor does not require routine replacement and is not poisoned like electro-chemical cells. This will save downtime and maintenance costs. The cell performance is consistent and does not drift as it is not consumed by the process.

The non-depleting sensor reduces service intervals and no regular replacement of cells is required. The casing unscrews to allow for easy access to the sensor, enabling maintenance of the modular components to be carried out quickly and efficiently.

### Easy installation with local display for use in hazardous areas

The XTP601 provides two isolated 4-20 mA outputs and is housed in a robust and weather-proof casing, allowing the analyzer to be placed at the point of measurement.

The closer the analyzer can be installed to the sample point, the better, for many reasons. These include, faster overall speed of response (for safety), less sample line or cabling (saves cost) greater choice of installation points (flexibility). Also having a local display does not require two operators (or walking back and forth to the control room) for maintenance or diagnostics.

### External sensor input

The unit has the facility to accept a 4-20 mA signal from an external source such as dew point sensor, pressure transmitter, temperature probe or user-defined sensor, and display it on the screen. This saves the cost of buying and installing an external display for another parameter that only requires occasional visual inspection.



Chemical plant

## Technology Thermo-Paramagnetic Sensor

Oxygen is a paramagnetic gas, which means that it is attracted by a magnetic field. This magnetic susceptibility is much greater for  $\text{O}_2$  than that of most other gas molecules and therefore this physical property is ideal for the determination of the level of oxygen in a wide range of background gases.

The XTP601 series is a thermo-paramagnetic oxygen analyzer where the combination of paramagnetic and thermal conductivity technology is exploited to accurately measure oxygen. The instrument is very stable which gives the user confidence in the measurement. This is important in safety applications such as blanketing of vessels or reactors in chemical plants.

In addition to the stability of the Michell XTP601 sensor, the insensitivity to mechanical shock is another advantage of the thermo-paramagnetic technology. As it relies solely upon fluctuations in magnetic fields and not internal moving parts, the sensor will operate efficiently under a wide range of environmental conditions. It is suitable for installation where vibration or movement could pose a problem for other sensor types.

## Flexible Packaging

The XTP601 is available in three configurations all with the option of Safe (GP) or Hazardous (EX) Area classification depending on the individual customer's needs. This allows the user to determine the price to feature ratio that best suits each installation.



**XTP601 (EX1 or GP1)**  
The full display model provides a local HMI for the user to access all the functions of the analyzer through the glass via capacitance buttons. As well as displaying the oxygen concentration there is a status bar showing messages. The user can scroll through the front screens to see a graph of the latest period (user defined), high & low oxygen points, reading from an external sensor and alarm history.



**XTP601 (EX2 or GP2)**  
This is similar to the blind transmitter, but has a window with power and status LEDs (alarm and/or fault) following the NAMUR standard.



**XTP601 (EX3 or GP3)**  
The basic model is a blind oxygen transmitter that provides 4-20 mA outputs, alarm relays & RS485 serial communications. There is application software included that allows the user to visualize and interact with the unit from their PC or control system. There is an optional light guide that will indicate that the unit is powered up and/or in alarm condition.



**Application Software**  
The XTP601 analyzer is supplied with application software that will allow the user remote access to the unit. This includes displaying the oxygen concentration, alarms, graphs, changing parameters and even remote calibration.

## OS601 Premium Sample Handling System for the XTP601

For a long, trouble-free life, oxygen analyzers invariably require a clean, dry gas that is free from particulates and at a suitable temperature and pressure. In the real world, the process gas to be measured almost never fulfils these requirements. Michell Instruments offer a complete solution for this problem: The XTP601 and OS601 Sample Handling System. This modular system is constructed in consultation with customers to ensure the best possible solution for each individual application.

### Flow Schematic for O<sub>2</sub> in Natural Gas

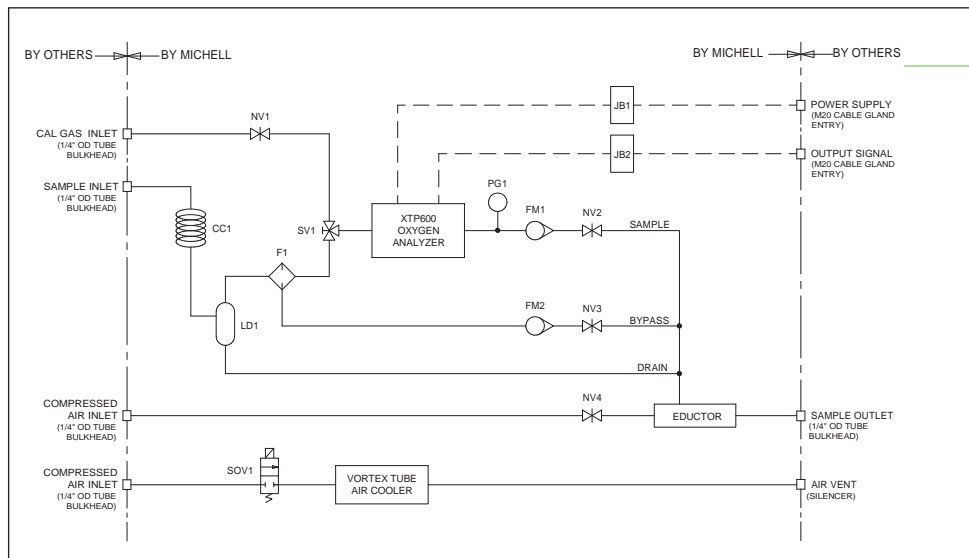

The sampling system shown is for use with 'misty' gases sampled in a hazardous area. It is one of the more complex sampling systems available.

The use of an eductor negates the issues of using a pump with hydrocarbons and reduces cost. There is also a vortex cooler to keep the system cabinet cool.

# Technical Specifications

Performance	
Measurement Technology	Thermo-paramagnetic oxygen sensor
Gas	Process and non-condensing sample with particles <3µm
Measurement Range	Selectable from 0-1% up to 0-50% and 80/90-100%
Display Resolution	0.01%
Display Type	Backlit LCD
Accuracy (excluding suppressed zero ranges)	< ±1% of span or ±0.02% O <sub>2</sub> whichever is greater
Accuracy for suppressed zero ranges (80/90-100%)	< 0.2% O <sub>2</sub>
Response Time (T90) with High Speed Response (HSR) enabled	< 15 seconds
Repeatability	±0.2% of span or 0.01% O <sub>2</sub> whichever is greater
Linearity	±0.5% of span or 0.05% O <sub>2</sub> whichever is greater
Zero Stability	±0.25% of span per month
Span Stability	±0.25% of span per month
Sample Flow Rate	100 to 600 ml/min (0.2 to 1.27 scfh)
Sample Flow Effect (calibrated at 300 ml/min (0.64 scfh))	< 1% of span for flows: 100 to 600 ml/min (0.2 to 1.27 scfh)
Sample Pressure	0 to 3 barg (0 to 43 psig)
Sample Temperature	0 to 55°C (+32 to +131°F) max (+45°C (+113°F) for standard cell)
Sample Cell Temperature	Standard +50°C (+113°F) (Optional +55°C and +60°C (+131°F and +140°F))
Background Gas	Unit can be calibrated in a user-defined background gas to increase the accuracy

Electrical Input/Output	
Analog Inputs	2 off 4-20 mA inputs One for an external sensor that can be displayed on the screen One to act as an active compensation for the process conditions
Analog Outputs	2 off 4-20 mA outputs (isolated)
Output Ranges	Primary range is set to the calibrated range of the instrument The second is user selectable within the primary range
Alarms	2 off single pole changeover (SPCO) relays for O <sub>2</sub> concentration (250 V, 5 A max)
Datalogging	The user can use the digital communications to log the output from the analyzer The unit will store 40 alarm points and the min/max O <sub>2</sub> concentrations with date and time stamp
Digital Communications	Modbus RTU over RS485 Protocol
Power Supply	24 V DC; 1.5 A max

Operating Conditions	
Ambient Temperature	-20 to +55°C (+4 to +131°F) (dependent on configuration)

Mechanical Specification	
Warm Up Time	< 30 minutes
Stabilization Time	15 minutes
Dimensions	234 x 234 x 172mm (w x d x h) (9.2 x 9.2 x 6.7") (w x d x h)
Weight	9.7kg (21.4lbs)
Wetted Materials	316 & 430F stainless steel, borosilicate glass, platinum, 3M 2216 (plus O-ring)
O-Ring Materials	Viton, Silicone or Ekraz
Gas Connection	1/4" NPT, 1/4" tube or 6mm tube
Ingress Protection	IP66, NEMA 4X

Hazardous Area Classifications	
ATEX	II 2 G Ex d IIB+H2 T3 Gb
IEC Ex	II 2 D Ex tb IIIC T137°C Db IP66 T amb -40°C to +55°C
CSA <sub>US</sub>	Class I, Division 1, Groups B,C,D

## Dimensions

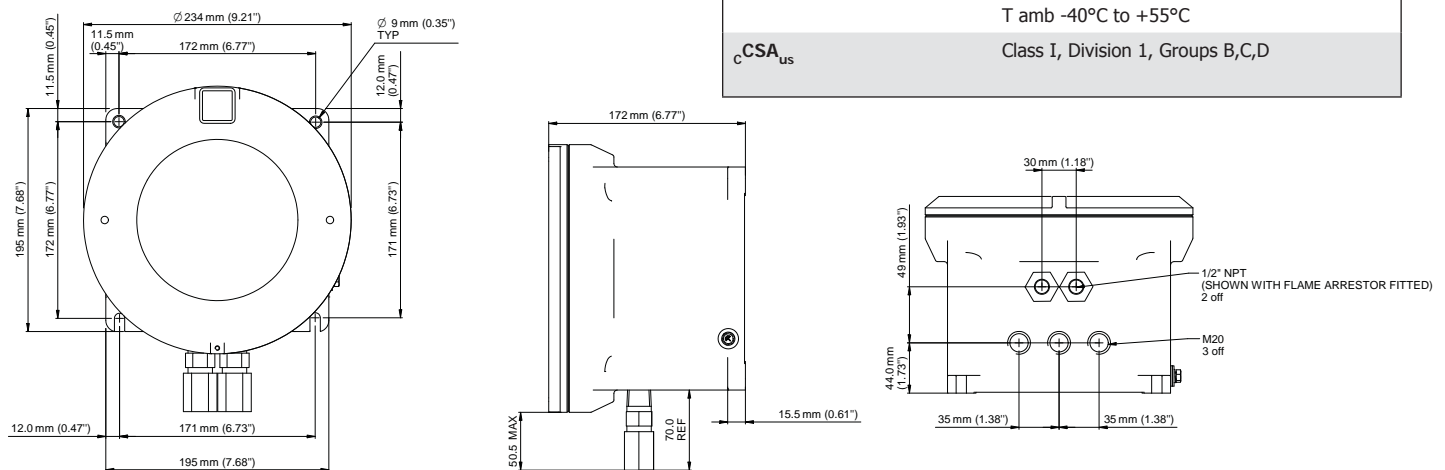

Michell Instruments, Inc 319 Newburyport Turnpike, Suite 207, Rowley, MA 01969  
 Tel: 978 484 0005, Fax: 978 843 7669, Email: us.info@michell.com, Web: [www.michell.com/us](http://www.michell.com/us)

Michell Instruments adopts a continuous development programme which sometimes necessitates specification changes without notice.  
 Issue no: XTP601\_97314\_V2\_US\_0912