

Cermet II

Hygrometer

The hygrometer of choice for the measurement of dew point, temperature, or gaseous moisture applications with a choice of units of measurement or where pressure compensation is required.



Ti Techingenium

Distribuidores autorizados para Uruguay
 Venta - Ingeniería - Instalación - Mantenimiento
 Dirección Jaime Zudañez 2516
 Teléfono: 2711 09 86
 Montevideo Uruguay
 Mail: info@techingenium.com.uy
 www.techingenium.com.uy

Highlights

- Wide measurement range, calibrated -100 to +20°C dew point (-148 to +68°F)
- ±1°C dew point measurement accuracy (±1.8°F)
- Pressure sensor input
- Up to 4 alarm relays
- User selectable units of measurement
- Easy to read display
- Analog and digital outputs

Applications

- Industrial gases
- Dried compressed air
- Welding gases
- Glove boxes
- Medical gases
- High voltage switchgear (SF₆)
- ... and many more

Cermet II Hygrometer

Complete On-Line Dew Point Solution

Cermet II is the intelligent choice for reliable on-line measurement of moisture in virtually any gas, across many applications. Cermet II combines Michell's Advanced Ceramic Moisture Sensor and a monitor unit that can be located up to 1200 m apart (3930 ft). While Cermet II is so simple to use, it has the flexibility to be applied to almost any humidity measurement application. The instrument can display measurement units in °C or °F dew point, ppm_v, lb/mmascf or g/m³ across the measurement range -100 to +20°C dew point (-148 to +68°F) at pressures up to 5000 psig. The Cermet II also can accept a pressure signal from a pressure transmitter (optional) providing the means of active pressure compensation for concentration units of measurement.

Cermet II Monitor

The Cermet II Monitor is a fully self-contained display system in a 1/8 DIN panel mounting case that indicates the measured humidity parameter and performs pressure compensation (if required). Cermet II also provides current and digital outputs and two 10 A alarm relays. It is protected to NEMA 12 and can be supplied with an optional front panel providing a NEMA 4X rating. Its operating temperature range is -20 to + 50°C (-4 to + 122°F).

Cermet II Sensor

The Cermet II Sensor uses Michell's Advanced Ceramic Moisture Sensor technology with on-board intelligence. This smart sensor has a measurement range of -100 to +20°C dew point (-148 to +68°F) at pressures up to 5000 psig and offers a superior measurement accuracy of better than ±1°C dew point from -60 to +20°C (±1.8°F from -76 to +68°F). From -100 to -60°C dew point the measurement accuracy is ±2°C dew point (±3.6°F from -148 to -76°F). The on-board processor in the sensor electronics enables excellent performance, reliability and interchangeability of sensors. Cermet II's sensor is designed to perform in harsh environments. Constructed in stainless steel, the sensor is also protected to NEMA 4 and has an operating temperature range of -40 to +140°F.

Extreme Flexibility

The dew point of any gas will vary with pressure. When calculating concentration units of measure, Cermet II can compensate for these variations either by using of a live pressure transducer input, or by using a pressure factor input via the instrument front panel.

For control of external devices Cermet II is supplied as with two 10 A, 240 VAC Form 'C', fully user configurable, alarms, standard. These can be set over the full operating range of the instrument, with variable hysteresis for any chosen engineering unit. The alarms can also be configured to flag sensor or cable fault conditions. An additional two alarms can be added if required.

Cermet II is supplied with a 4-20 mA output, which is fully configurable for range and scale, standard. In addition, a 2-way RS232 digital signal is provided which gives full data access to the user. Optionally a 0-10 V configurable analog output can be specified, as can an RS485 2-way digital port.

Intrinsically Safe Version

The Cermet II I.S. version adds intrinsic safety barriers with the monitor and the Transmet I.S. transmitter is used. See the Cermet II I.S. data sheet for the ideal solution for measurement and display of gaseous moisture in hazardous areas.

Applications

Cermet II can provide the solution to both energy management and quality assurance in the supply of pure gases and compressed air from heat regenerative, adsorption dryers. The durability of the Advanced Ceramic Moisture Sensor provides long term service in applications such as pipeline drying using vacuum and dry gas purging techniques.



Power station (Peterhead CS)

Technology

The Cermet I.S uses Impedence technology, based on Michell's ceramic sensor.

The Ceramic Sensor is constructed using state of the art thin and thick film techniques. Operation of the sensor depends upon the adsorption of water vapor onto a porous non-conducting "sandwich" between two conductive layers built on top of a base ceramic substrate. The active sensor layer is very thin - less than one micron (about 0.00004 inches) and the porous top conductor that allows transmission of water vapor into the sensor is even thinner. Therefore the sensor responds very rapidly to changes in applied moisture, both when being dried (on process start-up) and when called into action if there is moisture ingress into a process.

Despite this extreme sensitivity to changes in moisture content, the Michell Ceramic Moisture Sensor is incredibly rugged due to the nature of its construction. To protect the sensor further against contaminants and pipe swarf it is housed in a protective sintered stainless steel guard. All Michell Ceramic Moisture Sensors give $\pm 2^{\circ}\text{C}$ ($\pm 3.6^{\circ}\text{F}$) dew point accuracy and excellent long-term reliability and stability in process applications.

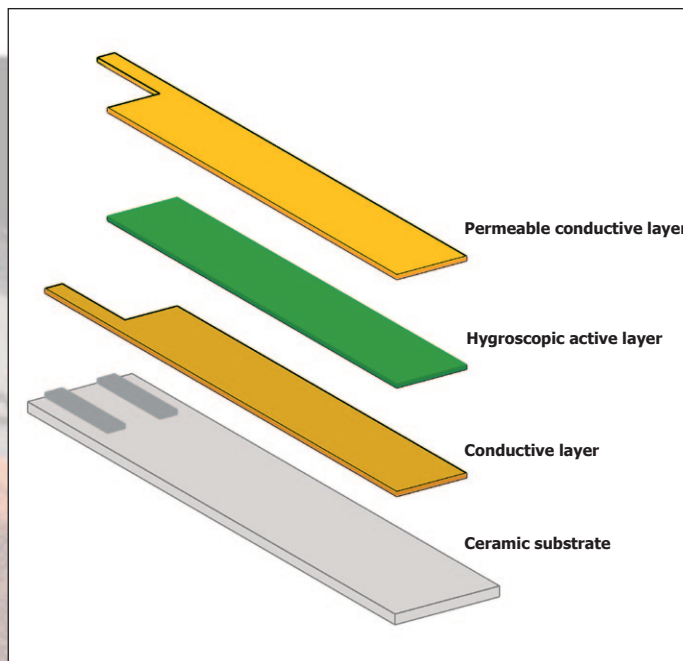

Michell ceramic sensor tile layers

Order Codes

Order codes	Product description	
CT2- {1} - {2} - {3} - {4} - {5}	CERMET II - Full specification On-Line Hygrometer complete with Monitor (1/8 Din), Sensor, 6' Cable, Sampling Block, 2 alarms, isolated 4-20mA and RS232 outputs	
Suffix {1} - Alarms configuration	A2	Standard 2 alarm relays
	A3	Three alarm relays
	A4	Four alarm relays
Suffix {2} - Analog output	mA	Standard 4-20 mA
	V	0-10V
Suffix {3} - Digital output	2	RS 232 standard output
	4	RS 485
Suffix {4} - Power supply	AC	Power Supply - 85/265 VAC
	DC	Power Supply - 24 VDC
Suffix {5} - Sensor cable	2	6' cable with connectors
	XXXX	Cable greater than 6' supplied in one single length with connectors - additional price per foot

Accessories

Order codes	Product description
CT2-SEN	Spare sensor for use with CERMET II Hygrometer
CSB	Stainless Steel Sample Block for use with Cermet II Sensor - 5/8" UNF thread with 1/8" NPT ports
APT-PAN	3/4"-16 UNF to 5/8" UNF male adapter, stainless steel, (Standard Panometrics thread)
APT-GEI	G 1/2" to 5/8" UNF male adapter, stainless steel, (Standard E&H or GEI thread)
CT2-IPC	Clear plastic cover for CERMET II Monitor to give environmental protection to NEMA4 (IP66)
CT2-CAB	Spare sensor cable, 6' length with connectors
EA2-SAM	Easidew Sampler - S/S block with :- filter cartridge (0.3micron), inlet/outlet push fittings, m-valve and PTFE vent tube 0.24" (6mm) dia. For atmospheric or pressure dewpoint measurements (150 psig max). Complete with mounting bracket
CT-MON	Replacement Cermet II Monitor

Technical Specifications

Sensor

Measurement Range	-100 to +20°C dew point (-148 to +68°F)
Accuracy (dew point)	±1°C from -60 to +20°C dew point (±1.8°F, -76 to +68°F) ±2°C from -100 to -60°C dew point (±3.6°F, -148 to -76°F)
Enclosure	Stainless steel
Ingress Protection	NEMA 4X
Operating Temperature	-40 to +60°C (-40 to +140°F) compensated over -20 to +40°C (-4 to +104°F)
Storage Temperature	-40 to +165°F
Operating Pressure	From vacuum to 5000 psig (max)
Flow Rate	1 to 5 l/min (2.1 to 10.5 scfh)
Gas Velocity	0 to 10m/sec (0 to 32.8 ft/sec)
Process Connection	5/8" UNF parallel thread
Sensor Calibration	Traceable to NIST

Analyzer

Measurement Units	°C, °F dew point; ppm _v with user selectable range and resolution; lb/mmscf range dependent on pressure (natural gas); g/m ³ (natural gas). Digital processing and linearization with active or passive pressure compensation				
Resolution	0.1 °C from -80 to +20°C dew point (0.18°F, -112 to +68°F) 1°C from -100 to -80°C dew point (1.8°F, -148 to -112°F)				
Secondary Measurement Variable	Pressure using an optional external transducer over a range of 0 to 4000 psig. Completely user-configurable for any industry standard transducer with an 4-20 mA output. Automatic compensation for ppm _v lb/mmscf and g/m ³ units.				
Alarm Relays	Two user adjustable isolated 10A form 'C' rated at 240VAC or 24VDC				
Outputs:	<table border="0"> <tr> <td>Analog</td> <td>4-20 mA as standard (max load 500 Ω) user configurable and scalable</td> </tr> <tr> <td>Digital</td> <td>RS485</td> </tr> </table>	Analog	4-20 mA as standard (max load 500 Ω) user configurable and scalable	Digital	RS485
Analog	4-20 mA as standard (max load 500 Ω) user configurable and scalable				
Digital	RS485				
Power Supply	Universal 85 to 265VAC, 50/60 Hz or 95 to 370VDC				
Operating Conditions					
Operating Temperature	<table border="0"> <tr> <td>Monitor:</td> <td>0 to +50°C (32 to +122°F)</td> </tr> <tr> <td>Sensor:</td> <td>-20 to +50°C (-5 to +122°F)</td> </tr> </table>	Monitor:	0 to +50°C (32 to +122°F)	Sensor:	-20 to +50°C (-5 to +122°F)
Monitor:	0 to +50°C (32 to +122°F)				
Sensor:	-20 to +50°C (-5 to +122°F)				
Ingress Protection	<table border="0"> <tr> <td>Monitor:</td> <td>IP54 (NEMA 12) standard (front panel only) IP66 (NEMA4) with optional cover (front panel only)</td> </tr> <tr> <td>Sensor:</td> <td>IP66 (NEMA4)</td> </tr> </table>	Monitor:	IP54 (NEMA 12) standard (front panel only) IP66 (NEMA4) with optional cover (front panel only)	Sensor:	IP66 (NEMA4)
Monitor:	IP54 (NEMA 12) standard (front panel only) IP66 (NEMA4) with optional cover (front panel only)				
Sensor:	IP66 (NEMA4)				

Options

Outputs	<table border="0"> <tr> <td>Analog:</td> <td>0-20 mA optional (max load 500 Ω) 0-10 V optional (min load 5 K Ω) both user configurable and scalable</td> </tr> <tr> <td>Digital:</td> <td>RS485: provides 2-way communication - full data access to user and total instrument configuration</td> </tr> </table>	Analog:	0-20 mA optional (max load 500 Ω) 0-10 V optional (min load 5 K Ω) both user configurable and scalable	Digital:	RS485: provides 2-way communication - full data access to user and total instrument configuration
Analog:	0-20 mA optional (max load 500 Ω) 0-10 V optional (min load 5 K Ω) both user configurable and scalable				
Digital:	RS485: provides 2-way communication - full data access to user and total instrument configuration				
Alarm Relays	1 or 2 additional 5 A relays (max 4 total) n/o type fully user configurable and adjustable over the full range, full choice of units and sensor fault alarm functions				
Power Supply	18 to 36 VAC; 9 to 60 VDC				
Cable	Standard 6.5 foot (4000 foot max)				

Dimensions

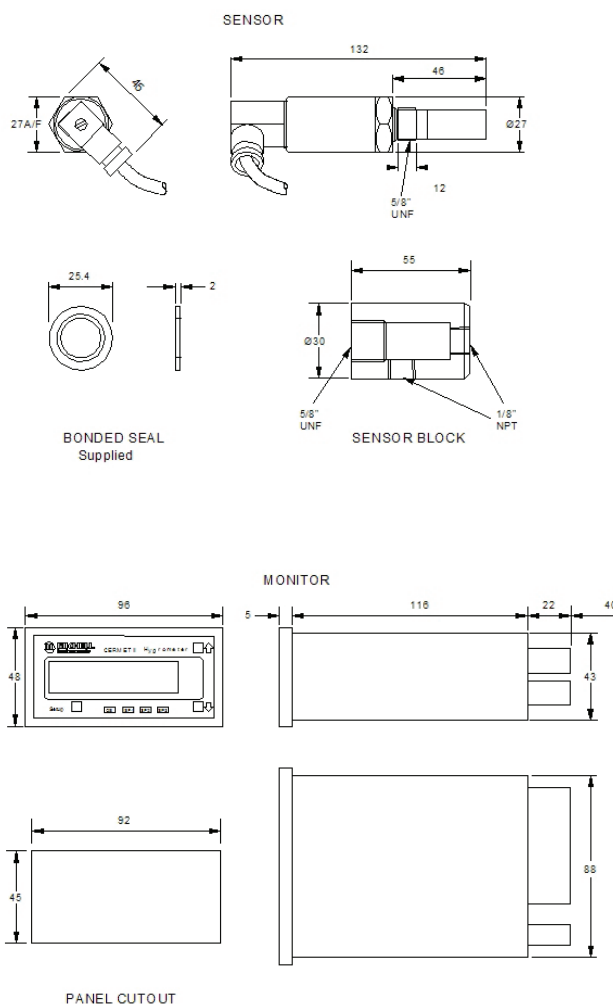

Michell Instruments, Inc 319 Newburyport Turnpike, Suite 207, Rowley, MA 01969
Tel: 978 484 0005, Fax: 978 843 7669, Email: us.info@michell.com, Web: www.michell.com/us

Michell Instruments adopts a continuous development programme which sometimes necessitates specification changes without notice.
Issue no: Cermet II_97169_V1_US_0110_4pp