



UNIBOX

Made of hot-pressed glassfibre reinforced polyester
Two-part construction
Low flammability and self-extinguishing

- Colour similar light grey, RAL 7032
- UV-resistant
- EPDM seal
- Protection class IP65

For further technical details see [KD015](#)

Heat Transition Coefficient K		J 1	J 2	J 3	J 4
Standard	without window	4,4	4,6	4,8	5,0
	with window	4,9	5,1	5,3	5,5
arctic-Alu (only lid)	without window	2,3	2,5	2,7	3,0
	with window	2,7	3,0	3,3	3,5

Application

The enclosures of the UNIBOX series have been designed in two-parts with a straight, horizontal parting line between the upper and the lower part. This type of construction allows for maximum accessibility during installation or maintenance of differential pressure transmitters and the associated manifolds. The removable or hinged lid allows cable entries from the front, rear, sides or bottom.

Designs

- SV** 2 clasps in stainless steel
- SE** 2 hinges and 2 clasps in stainless steel
- DFVA** lid propstay in stainless steel, fitted

Window

- FS** safety glass window
 - Ø 200 (only front)
 - 290 x 210 mm
- window mounting in
 - left
 - right
 - top

arctic additional Insulation

with PU foam, not stackable

- arctic-Alu** Alu-foil (only lid insulated)

Explosion protection

- GO** antistatic to avoid electrostatic charges according to EN IEC 60079-0

Vents and Drains (see data sheet [KD184](#))

- LF** Labyrinth Filter IP44
- DV** Breather Drain IP66

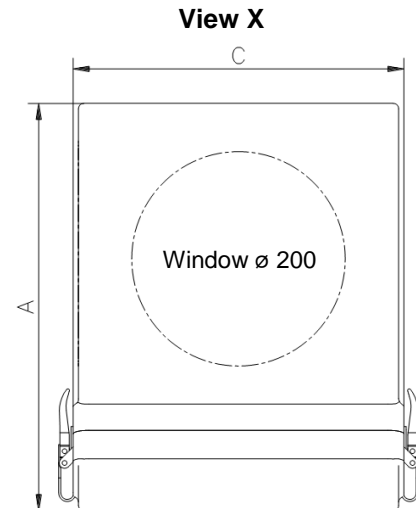
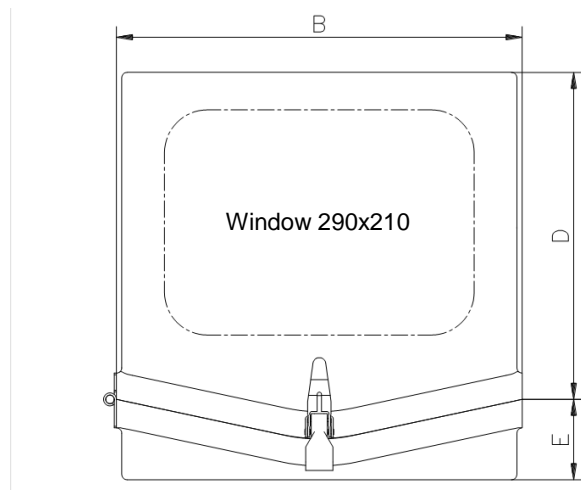

Dimensions (mm) and weight (kg)

UNIBOX	A	B	C	D	E	weight
Type J 1	380	380	310	305	75	5,2
Type J 2	420	380	310	305	115	5,5
Type J 3	480	380	310	405	75	6,5
Type J 4	520	380	310	405	115	6,8

Ordering example: UNIBOX J1 SV FS arctic-Alu GO

Ti Techingenium

Distribuidores autorizados para Uruguay
Venta - Ingeniería - Instalación - Mantenimiento
Francisco Soca 1531
Montevideo Uruguay
Telefono: +598 2 707 48 01
Mail: info@techingenium.com.uy
www.techingenium.com.uy