



# SD17 Switch Protection Canopy

Made of hot-pressed glassfibre reinforced polyester.  
Low flammability and self-extinguishing.

## Optional design

	Standard	Option GO
colour	similar to RAL 7032 light grey	similar to RAL 7001 silver grey
	similar to RAL 3000 fire red	similar to RAL 3000 fire red
anti-static	n/a	antistatic to avoid electrostatic charges according to EN IEC 60079-0



Example of an application  
(the switch is not included in the supply)

## 1 Application

Chemical or oil and gas plants, i.e. refineries, are often open-air plants. Emergency buttons and local control switches are subject to rough mechanical and environmental conditions. Malfunction often causes operation problems.

Background to the development was a falling part of a scaffolding that hit an emergency shut off button of a German refinery and caused a damage of several million euros.

## 2 Special Advantages

- Fits single and multiple switches
- Very stable. Top shaped like a torus, reinforced edges, reinforced switch mounting area
- Stable SMC GRP material, long fibre reinforced polyester, high wall thickness.
- Passed 'resistance to impact' test according to IEC 60079-0 at the highest level.
- The optional front bar provides protection against accidental misuse, but does not impair manual operation (even with work gloves). It can be glued or bolted at different heights by the customer.
- Flat space for a tag at the front bar

## 3 Dimensions

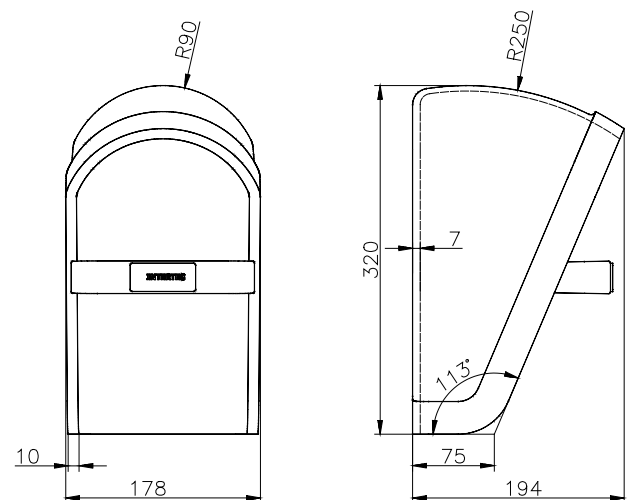

## 4 Mounting Accessories

Installation accessories are available, i.e. pipe clamp RS21

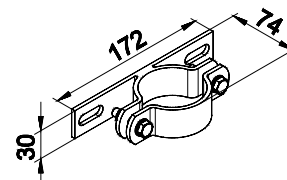

**Ti** Techingenium

Distribuidores autorizados para Uruguay  
Venta - Ingeniería - Instalación - Mantenimiento  
Francisco Soca 1531  
Teléfono: +598 2 707 48 01  
Montevideo Uruguay  
Mail: info@techingenium.com.uy  
www.techingenium.com.uy