

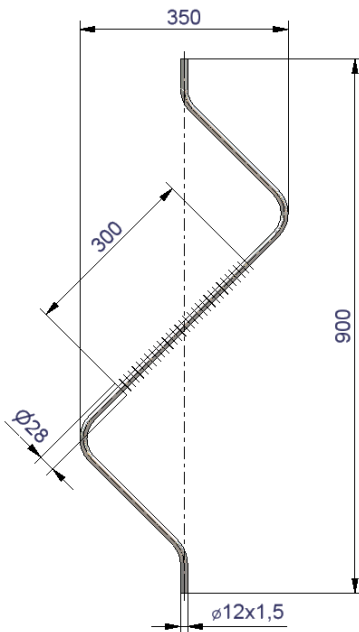

Steam Heating Tubes DHD, DHW, DHU and ALUSTEAM

DHD

Steam heating tube of stainless steel or galvanized.
For protection-box types 60-170



DHW 100 / DHW 150

Steam heating tube of stainless steel or galvanized
DHW100 for protection-box types 60,70,100
DHW150 for protection-box types 80,150,170

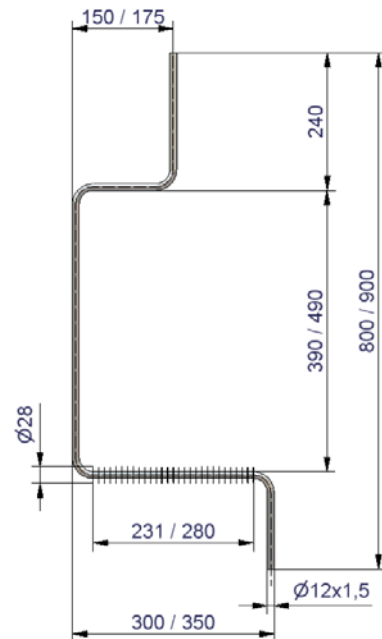

DHU

Steam heating tube of stainless steel.
For all protection-boxes.

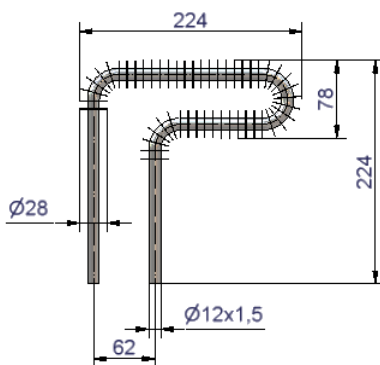

ALUSTEAM 150

Aluminium-radiator with stainless steel steampipe
For all protection-boxes.

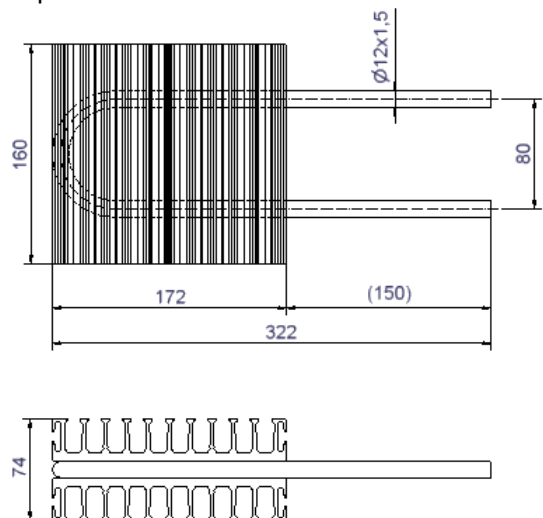

Installation:

Drill 2 holes into INTERTEC-protection-box, insert wall bushing WDD12/25, push heating tube from the inside outwards and connect the ends with steam- and condensate conduit. Mounting fittings are not included.

Comment:

Other designs for other heating media e.g. hot water, on request.



Distribuidores autorizados para Uruguay
Venta - Ingeniería - Instalación - Mantenimiento
Francisco Soca 1531
Teléfono: +598 2 707 48 01
Montevideo Uruguay
Mail: info@techingenium.com.uy
www.techingenium.com.uy