

Chem

Energy

Pharm

Food

Water

Uniclean® 900

The electro-pneumatic controller for fully automated pH measurement and cleaning

In combination with the Protos® process analysis system and the SensoGate® or Ceramat® sensor lock-gates, Uniclean® offers the ideal functionality of a complete system for automatic process control of a pH measurement.

Maximum availability of the point of measurement: Cleaning without interrupting the process, even when measuring directly in the pressure tank

Since the sensor is not removed for cleaning, the process can continue uninterrupted. This allows problem-free measurements in a pressure tank or in the main pipe. Elaborate and lockable bypasses are eliminated and accuracy increases.

Low maintenance

Fully automated cleaning of the sensor with water or special cleaning solution at user-defined intervals without interrupting the process. The cleaning solution is automatically pumped into the cleaning chamber. You just have to top up the container.

Cost-efficient

Low-wear and low-maintenance pump with extremely low consumption of cleaning agent.

Long sensor life – also in critical processes

When measuring in aggressive media or at high process temperatures, the sensor rests in the cleaning chamber and is only briefly moved into the process for measurement. The cleaning chamber may be filled with water. This method decisively increases the sensor life.

Safe and easy measurement, even in strongly polluted media

Sensor cleaning and rinsing are performed at user-defined intervals. Cleaning solution and water are automatically pumped into the calibration chamber. Dismounting and manual cleaning of the sensor are not required.

Modern fieldbus integration

The interfaces to PROFIBUS PA or FOUNDATION Fieldbus allow the Uniclean® system to be integrated directly in a fieldbus network. Naturally also in hazardous locations.

Universal adaptation to retractable fittings

The modular structure of the Uniclean® allows any retractable fittings to be used. Optimum functionality is achieved with the Ceramat® and SensoGate® sensor lock-gates.

The Uniclean® 900 allows highly accurate measurements to be taken, even under difficult process conditions such as high pressure, high temperatures, and high levels of impurities. The device can be installed next to the process, within the hazardous area. Control is via the Protos® 3400 measuring system or directly via a DCS.

Clean and safe construction

All features for smooth, safe, and low-maintenance operation are provided as standard: water pressure gauge, air filter and water trap, integrated flooding sensor with alert message.



Polished stainless steel for food and pharmaceutical applications



Powder-coated steel for corrosive environments

Facts

- consistent enclosure concept for all devices
- modular design, adaptable to virtually every measuring task
- easy assembly and retrofitting
- hygienic version (polished stainless steel) or corrosion-proof (powder-coated steel)
- low maintenance effort due to innovative pump technology and extremely low consumption of media
- time-controlled cleaning
- cleaning with water and additional cleaning solution
- reduced maintenance effort due to automatic cleaning
- no disruption of production for cleaning the sensor
- operation in hazardous locations Zone 1 (all system components)
- longer sensor life due to short-time measurement and regular cleaning
- immediate readiness for measurement after production interruption since sensor is safely stored in liquid
- safety ensured by monitoring of the compressed air and water supply, the probe position and the cleaning solution level

Inside View

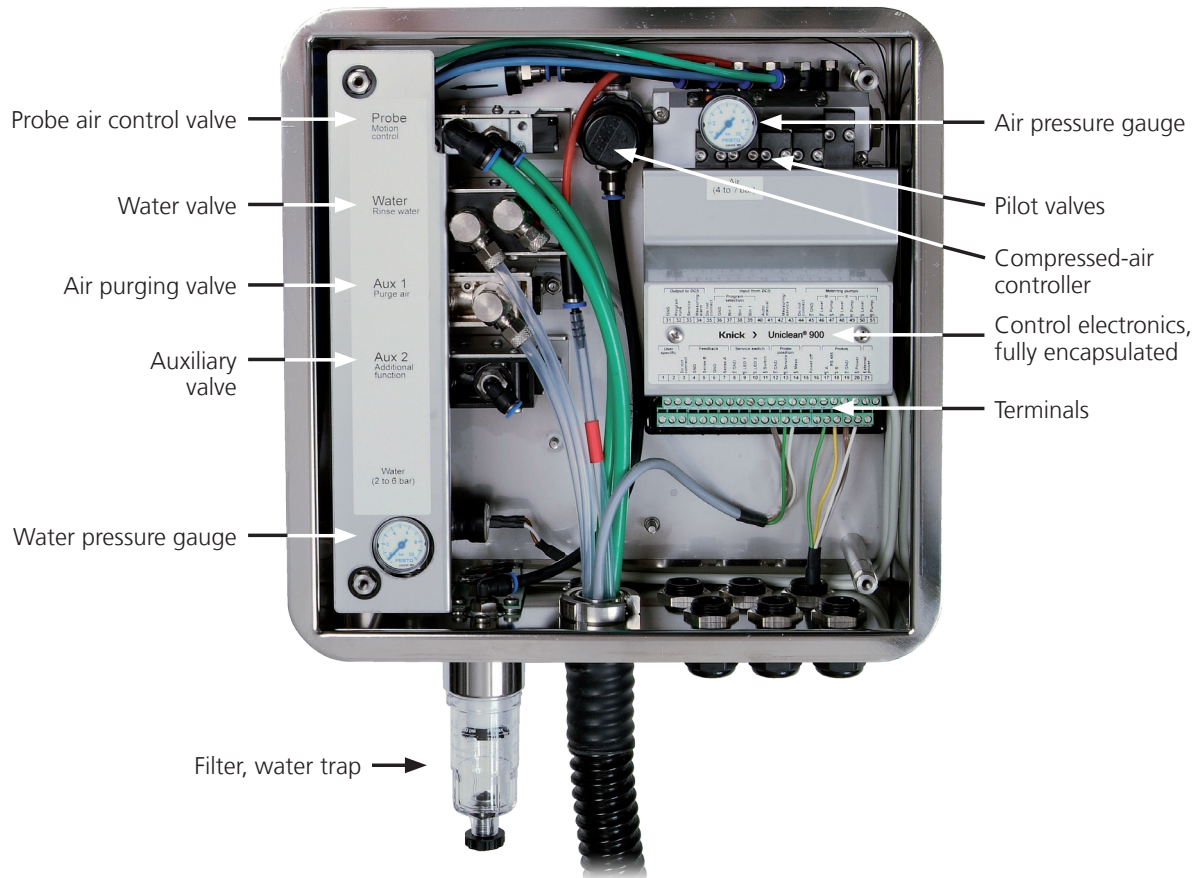

The valve units are expandable.

Control Systems

Chem

Energy

Pharm

Food

Water

Uniclean® 900

New, Innovative Pump Design for Low Maintenance Costs

- no usual pistons/cylinders
- no moving mechanical parts
- no wear
- no stored energy as defined in ATEX 94/9/EC
- all process-wetted parts are chemically resistant



Modular Flexibility for Very Simple Adaptation

- The cleaning solution container (3.5 l) is a replaceable active, self-sustaining unit with integrated pump: easy refilling of cleaning agent, without removing the pump
- The pump unit is automatically recognized by the system.
- The closure consists of a conveyor cap with funnel and buttoned lid.
- This innovative construction provides previously unknown flexibility and service friendliness.

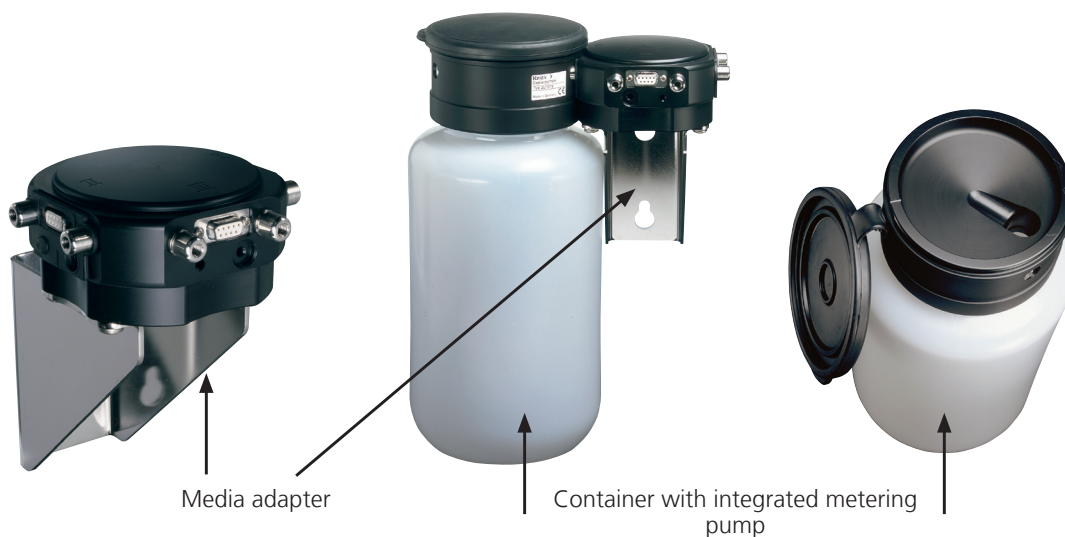

For up-to-date information, please visit www.knick-international.com

Isolation Amplifiers
Transmitters

Indicators

Process Analytics

Portable Meters

Laboratory Meters

Sensors

Fittings

Knick >

Overview – The Complete System

Protos® 3400
process analysis system



Uniclean® 900
controller



Metering pump
with cleaning solution



SensoGate® WA 130
sensor lock-gate



pH sensor

Control Systems

Chem

Energy

Pharm

Food

Water

Uniclean® 900

Specifications

Compressed air	oil- and condensate-free
Permitted pressure range	4 ... 10 bar
Pressure monitoring	automatic monitoring, message
Connection	1/4" internal thread
Rinse water	filtered 100 µm
Permitted pressure range	2 ... 6 bar
Temperature range	5 ... 65 °C
Pressure monitoring	automatic monitoring, message
Connection	1/4" internal thread and 3/4" external thread (for coupling)
Pump (option)	cleaning solution
Usable bottle volume	3.5 l
Max. lifting height	10 m
Displaced volume	25 ml/stroke
Level monitoring	continuous, messages
Material	PP, PE, EPDM, (optional FKM), check valves: glass, HC4
Dimensions	150 mm x 150 mm x 340 mm with 3.5-L bottle
Weight	approx. 1.5 kg (with empty 3.5-L bottle)
Supply	supplied via Protos® PHU module
(Ex ia IIC)	$V_i = 8.5 \text{ V}$ $I_i = 200 \text{ mA}$ $P_i = 400 \text{ mW}$ $6.8 \text{ V} (\pm 10 \%) / 15 \text{ mA}$
Connection	terminals, conductor cross section max 2.5 mm ² (preassembled connecting cable to Protos® 3400)
RS 485	communication with Protos® PHU module or external host computer (e.g. DCS/PLC)
(Ex ia)	$V_i/V_o = 5 \text{ V}$ $I_i/I_o = 250 \text{ mA}$ $R_i = 20 \text{ ohms}$
Transmission	1200 bauds/8 data bits/1 stop bit/no parity
Security	CRC16
Connection	terminals, conductor cross section max 2.5 mm ² (preassembled connecting cable to Protos® 3400) max. length 10 m
Media connection	compact multiplug connection for 1 x rinse water, 1 x cleaning liquid, 1 x purge air, 2 integrated check valves for water and cleaning liquid, 2 x compressed air connection for drive, noncontacting electrical limit position control
Media adapter	approx. 2 kg
DCS Input M/S	measuring/Service
(Ex ia IIC)	$V_i = 30 \text{ V}$, floating, galvanic isolation up to 60 V
Switching voltage	0 ... 2 V AC/DC inactive (measuring) 10 ... 30 V AC/DC active (service)

Specifications – continued

Connection	terminals, conductor cross section max. 2.5 mm ²
DCS input A/M	automatic mechanism blocked
(Ex ia IIC)	Vi = 30 V, floating, galvanic isolation up to 60 V
Switching voltage	0 ... 2 V AC/DC inactive (automatic intervals enabled) 10 ... 30 V AC/DC active (automatic intervals blocked)
Connection	terminals, conductor cross section max. 2.5 mm ²
DCS inputs PRG1 ... 3	program selection 1 ... 8
(Ex ia IIC)	Vi = 30 V, floating, inter-connected, galvanic isolation up to 60 V
Switching voltage	0 ... 2 V AC/DC inactive 10 ... 30 V AC/DC active
Connection	terminals, conductor cross section max. 2.5 mm ²
DCS outputs ML1 ... 3	check-back signals: Service, measuring, program electronic relay contacts, floating, inter-connected
(Ex ia IIC)	Vi = 30 V li = 100 mA Pi = 800 mW, galvanic isolation up to 60 V
Voltage drop	< 1.2 V
Connection	terminals, conductor cross section max. 2.5 mm ²
Explosion protection	II 2(1)G Ex ia IIC T4
EMC	EN 61326 EN 61326/A1
Lightning protection	EN 61000-4-5, Installation Class 2
Protection against electric shock	according to EN 61010
Ambient conditions	5 ... 55 °C (Ex: 5 ... 50 °C)
Ambient temperature	(different temperature range on request)
Transport/Storage temperature	-20 ... +70 °C
Relative humidity	10 ... 95 %, not condensing
Enclosure	Uniclean® 900 S Stainless steel A2, polished Uniclean® 900 C Stainless steel A2, coated, color: pigeon blue
Assembly	wall and pipe mounting (see dimension drawing)
Dimensions	W x H x D approx. 320 mm x 400 mm x 120 mm
Ingress protection	IP 65/NEMA 4X
Cable glands	4 cable glands M 20 x 1.5
Weight	approx. 9 kg

Control Systems

Chem

Energy

Pharm

Food

Water

Uniclean® 900

Product Line

Order No.

Basic unit		Uniclean® 900 /											
		<input type="checkbox"/>	<input type="checkbox"/>	<input type="checkbox"/>	<input type="checkbox"/>	<input type="checkbox"/>	<input type="checkbox"/>	<input type="checkbox"/>	<input type="checkbox"/>	<input type="checkbox"/>	<input type="checkbox"/>	<input type="checkbox"/>	<input type="checkbox"/>
Approvals	for hazardous area Zone 1 without	X	N										
Enclosure	steel, coated stainless steel, polished	C	S										
Media connection (water rinsing)	5 m (sealing material: FKM) 10 m (sealing material: FKM) 15 m (sealing material: FKM)	1	2	5	0	0	0						
Media connection (water rinsing and cleaning agent)	5 m (sealing material: FKM) 10 m (sealing material: FKM) 17 m (sealing material: FKM) 5 m (sealing material: EPDM) 10 m (sealing material: EPDM) 17 m (sealing material: EPDM)	3	4	6	C	D	F	1/A	1/A	1/A	1/A	1/A	1/A
Media interface	with (for standard probes) without (for WA 130, WA 150, WA 160)	1	0										
Media adapter with port	with (sealing material: FKM) with (sealing material: EPDM) none	1	A	0									
Port	metering pump with empty 3.5-L bottle (EPDM) metering pump with empty 3.5-L bottle (FKM) not equipped	2	B	0									
Supplementary air purging kit	with without							C	N				
Supplementary ext. valve kit	1 external valve none								E	N			
Special variant	none										0	0	0

Accessories for Uniclean® 900

Order No.

Pipe-mount kit for Uniclean® 900	ZU 0601
Pipe-mount kit for media adapter	ZU 0606
Connection kit for Uniclean® 900 (water and air)	ZU 0656
Commissioning Uniclean® 900 Commissioning comprises the following steps: – Connection of hoses and cables and commissioning of the Uniclean® 900 system. – Training of operators Prior to arrival of our engineer, the customer must prepare the following: – Protos® 3400, Uniclean® and retractable fitting assembled (Observe maximum length of connecting hose between Uniclean® 900 and retractable fitting). – Electric supply: Cable ducts/rails must be present. Auxiliary power supply for Protos® 3400 must be installed in 2 x 1.5 mm. – Air supply: Hose with connection nipple G 3/4" internal thread. Nominal hose width > 6 mm. Water supply: Hose with connection nipple G 3/4" internal thread or G 3/4" external thread. Nominal hose width > 6 mm.	ZU 0649
Chemical pump (supplementary ext. valve kit required)	ZU 0741

Spare Parts and Retrofit Parts for Uniclean® 900

Order No.

Media connection, rinse, 5 m (FKM gaskets)	ZU 0572/1
Media connection, rinse, 5 m (EPDM gaskets)	ZU 0572/2
Media connection, rinse, 10 m (FKM gaskets)	ZU 0573/1
Media connection, rinse, 10 m (EPDM gaskets)	ZU 0573/2
Media connection, rinse, 15 m (FKM gaskets)	ZU 0652/1
Media connection, rinse, 15 m (EPDM gaskets)	ZU 0652/2
Media connection, rinse + clean, 5 m (FKM gaskets)	ZU 0574/1
Media connection, rinse + clean, 5 m (EPDM gaskets)	ZU 0574/2
Media connection, rinse + clean, 10 m (FKM gaskets)	ZU 0575/1
Media connection, rinse + clean, 10 m (EPDM gaskets)	ZU 0575/2
Media connection, rinse + clean, 17 m (FKM gaskets)	ZU 0653/1
Media connection, rinse + clean, 17 m (EPDM gaskets)	ZU 0653/2
Media interface for standard probes	ZU 0576
Metering pump (PP, FKM) with empty 3.5-L bottle	ZU 0580/1
Metering pump (PP, EPDM) with empty 3.5-L bottle	ZU 0580/2
Metering pump (PP, FKM) with empty 3.5-L bottle, Ex	ZU 0580 X/1
Metering pump (PP, EPDM) with empty 3.5-L bottle, Ex	ZU 0580 X/2
Supplementary air purging kit	ZU 0587
Supplementary Aux 2 kit	ZU 0588
Media adapter (FKM gaskets)	ZU 0715/1
Media adapter (EPDM gaskets)	ZU 0715/2
Media adapter, Ex (FKM gaskets)	ZU 0715 X/1
Media adapter, Ex (EPDM gaskets)	ZU 0715 X/2

Control Systems

Chem

Energy

Pharm

Food

Water

Uniclean® 900

Service Parts for Uniclean® 900

Order No.

Air pressure switch	ZU 0632
Water pressure switch	ZU 0633
Probe valve, complete	ZU 0634
Water valve	ZU 0714
Sensor dismount guard, complete	ZU 0644
Air purge valve, complete	ZU 0636
Aux 2 valve, complete	ZU 0637
Piezo valve for valve block	ZU 0638
Gasket for port at media adapter (EPDM)	ZU 0639
Filter insert (5 ... 10 µm)	ZU 0640
Replacement filter housing	ZU 0641
Electronics module, tested, encapsulated	ZU 0716
Electronics module, tested, encapsulated, Ex	ZU 0716 X
Small-parts set (various screws, springs etc.)	ZU 0643
Multiplug service set, FKM gaskets	ZU 0812/1
Multiplug service set, EPDM gaskets	ZU 0812/2
Reed switch, short (service part for multiplug)	ZU 0813/1



Dimension Drawings

Wall mounting

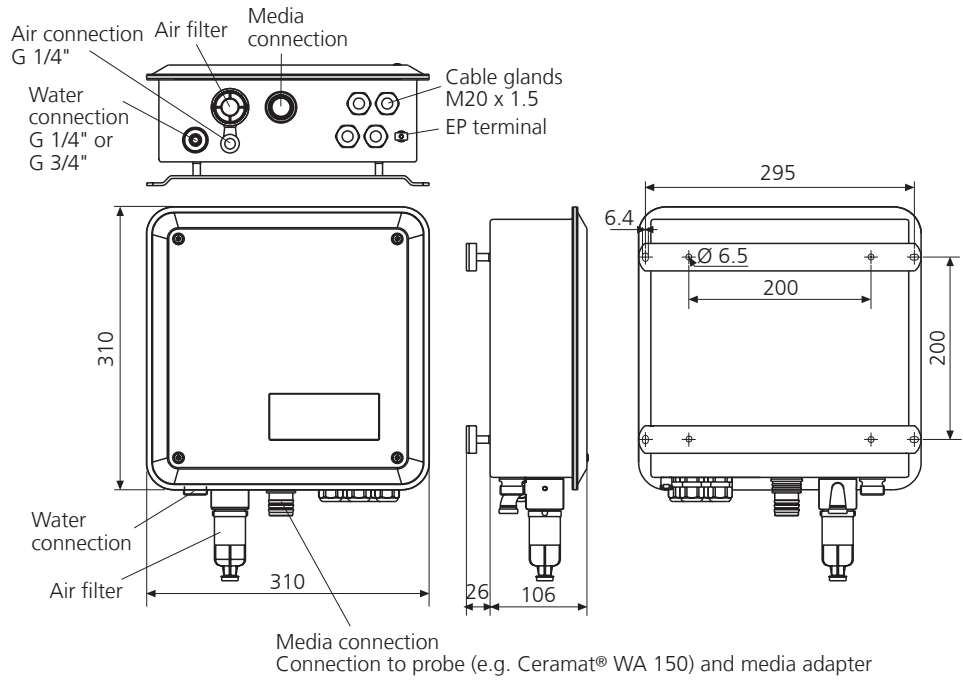

Pipe mounting

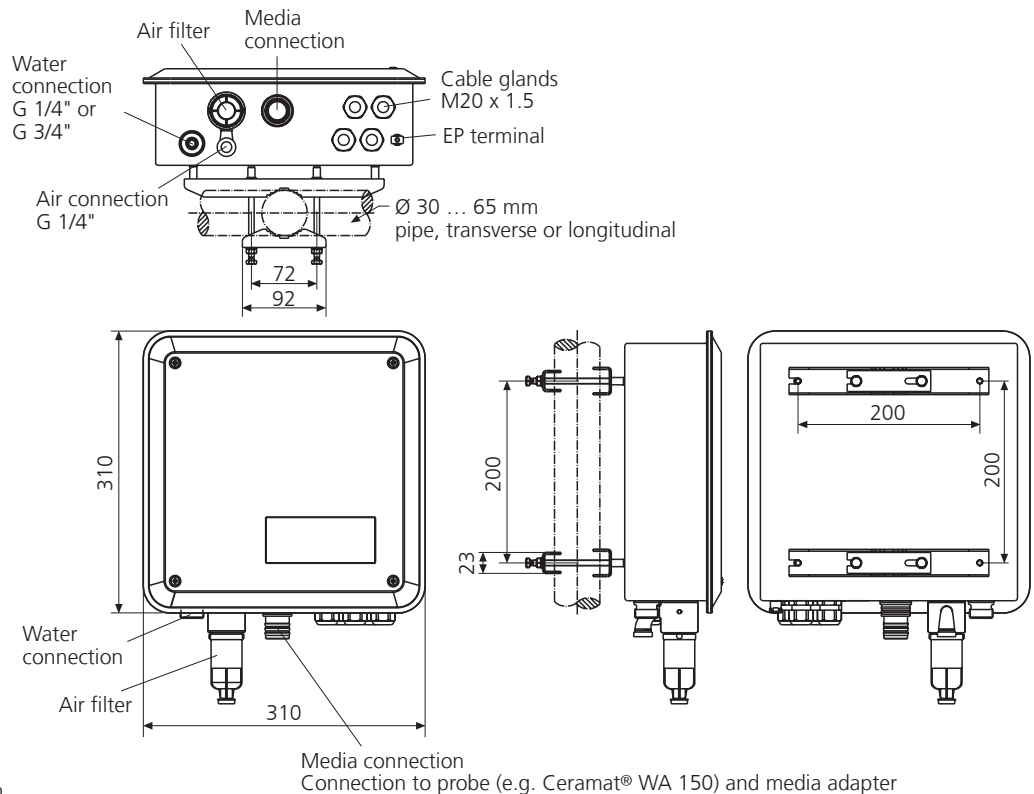

All dimensions in mm.

Control Systems

Chem

Energy

Pharm

Food

Water

Uniclean® 900

Dimension Drawings – continued

Pipe mounting

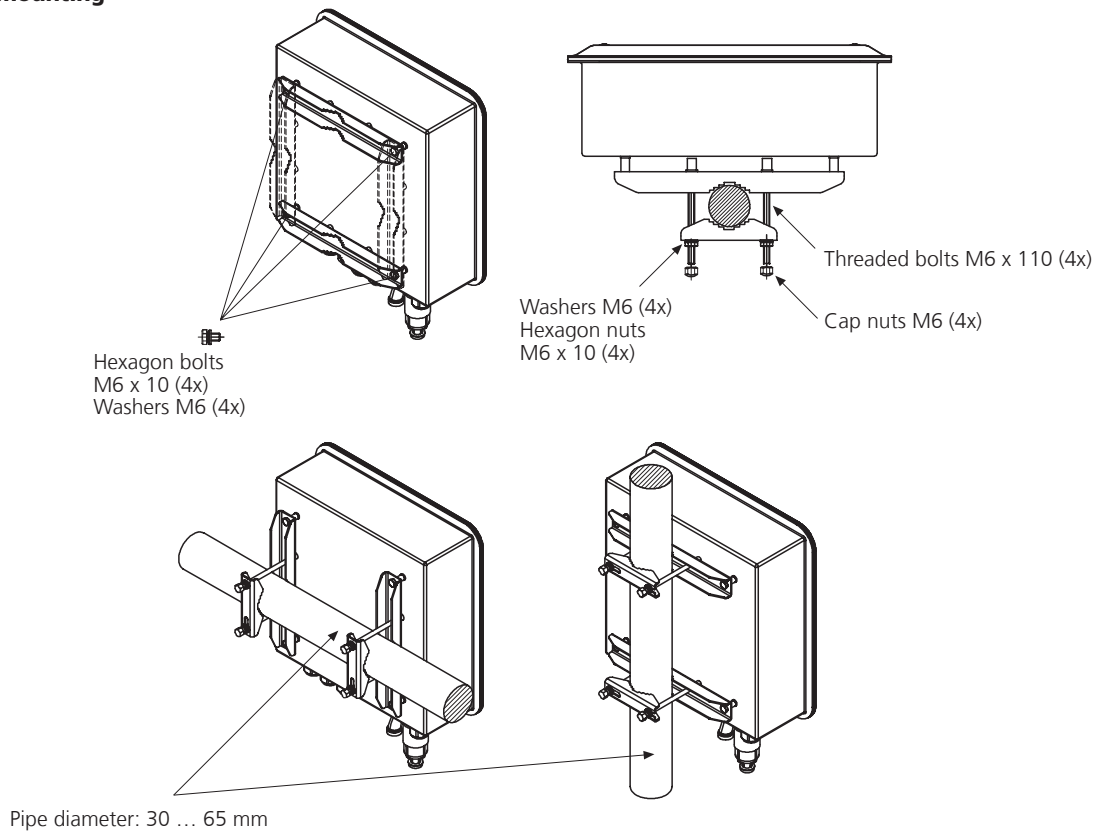

Media adapter

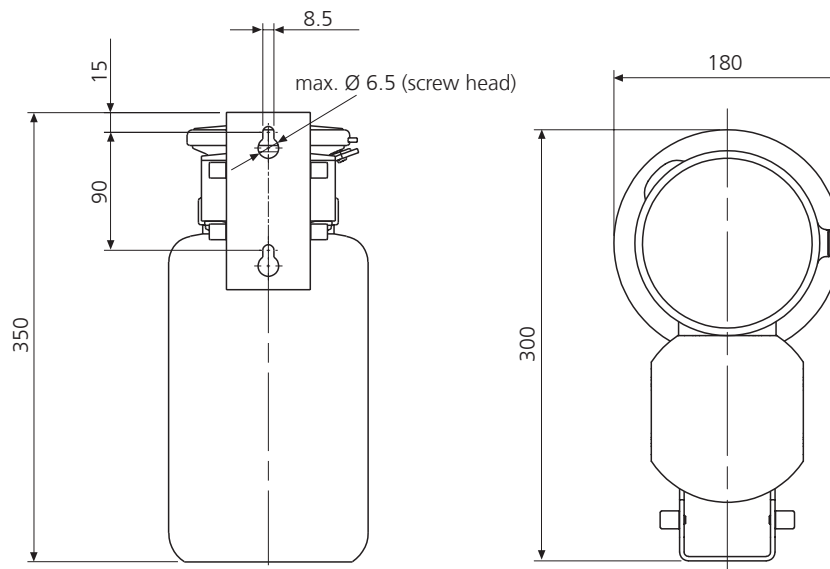

All dimensions in mm.

For up-to-date information, please visit www.knick-international.com



Terminal Assignments

