

Chem

Energy

Pharm

Food

Water

SensoGate® WA 130

Pneumatic sensor lock-gate for demanding fully automated process applications

Easy installation and clear hose connections

SensoGate® WA 130 offers genuine Plug & Play: The central multiplug is simultaneously linked via a single connection to all rinsing, cleaning, and calibration media as well as the control air and limit position mechanisms.

With the complete interior media routing and the multiplug, the connection is just as safe as it is convenient. Media entrainment is minimized and the limit-position mechanism is reliably protected.



SensoGate® with central multiplug

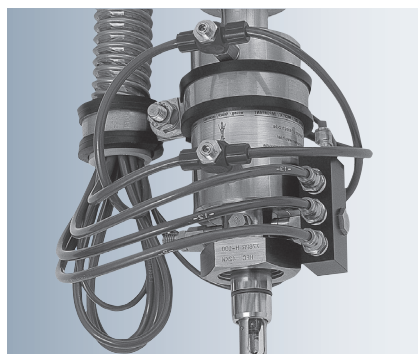

Conventional retractable fittings: Tangled hoses (left) and deposits on unprotected limit-position mechanism (right)

Systematic, Fully Automatic Liquid Analysis

The combination of the SensoGate® WA 130 retractable fitting with the Unclean® 900 (cleaning) or Unclean® 9000 (cleaning and calibration) control units and the Protos® 3400 measuring system enables fully automated measuring stations with an outstandingly high level of precision and reliability. The system offers the highest levels of safety with monitoring of the compressed air and water supply, the probe position, and the buffer and cleaning solution levels.

Maximum stability and precision due to patented metering-pump technology with separate routing of the media. Short-time measurements and regular cleaning enable longer sensor life. The production process is neither interrupted by automatic cleaning nor by calibrations (for further information, see Controllers chapter from page 306).

Facts

- compact, smooth, and dirt-resistant design with interior media routing and integrated limit-position mechanism
- minimum maintenance costs and maximum flexibility thanks to completely modular design
- very simple replacement of gaskets due to divided calibration/cleaning chamber
- increased service life and reduced seal wear
- ATEX approval II 1GD c II for the complete fitting
- cost reduction by simple installation, operation, and maintenance
- very high availability
- protective rinsing of the seals for a long service life
- SensoLock for high safety of operation
- integrated check valves and limit switches
- fast and uncomplicated replacement of calibration chamber and immersion tube
- all maintenance can be performed on site
- cyclone rinsing for optimum cleaning effect
- superior sensor immersion depth
- standard sensor length (225 mm) even for large immersion depths
- multiple process connections available
- flange version with scraper ring
- modular design allows specific replacement of the process-wetted materials: PEEK, PVDF, PP, 1.4571, Hastelloy
- plastic versions with high pressure and temperature resistance due to carbon-fiber-reinforced plastics
- special version for sensors with pressurizable liquid electrolyte

Pneumatic Retractable Fittings

Chem

Energy

Pharm

Food

Water

SensoGate® WA 130 for process applications

Specifications

Ambient temperature

5 ... 70 °C

Permissible process temp

1.4571, Hastelloy: 5 ... 140 °C
PEEK HD, PVDF HD: 5 ... 120 °C (temporarily 140 °C, 30 min)
PEEK, PVDF: 5 ... 100 °C

Permitted process pressure during movement

6 bars overpressure at 140 °C (1.4571/Hastelloy)
6 bars overpressure at 120 °C (PEEK HD/PVDF HD)
3 bars overpressure at 140 °C for 30 min (PEEK HD)
6 bars overpressure at 40 °C, 1 bar at 100 °C (PEEK/VDF)

Permissible static pressure

16 bars (40 °C) in service position

Air supply

4 ... 7 bars, filtered 10 ... 25 µm, oil- and condensate-free

Effective immersion depth

65 mm or 120 mm, measured from lower edge of flange to sensor tip (flange version)

Total immersion depth incl. immersion tube

88 mm or 143 mm (flange version)

Process adaptations*)

lapped flanges DN 32/DN 50/DN 65/DN 80/DN 100
lapped flanges ANSI 316, 1 1/2" / 2" / 2 1/2" / 3"
dairy-pipe screw joint DN 50/DN 65/DN 80/DN 100
Ingold socket 25 mm (G 1 1/4")

Sensors

225 mm, Pg 13.5 coupling,
250 mm for pressurized liquid electrolyte sensors

Rinse-medium inlet

1) for Unical® 9000/Uniclean® 900: Connection with hose grommet and coupling
2) for manual control: ZU 0631/ZU 0646
3) for free hose connection: 6/4 mm

Rinse-medium outlet

connection: hose grommet with coupling

Rinse function

seal rinsing during stroke movement

Process-wetted materials

stainless steel 1.4571, Hastelloy
PVDF, PVDF HD (carbon-fiber-reinforced)
PEEK, PEEK HD (carbon-fiber-reinforced)

Enclosure

stainless steel, 1.4571

Ingress protection

IP 66

Connection to Uniclean® 900/Unical® 9000

compact multiplug connection

Free hose connection

1 x 4/6 mm hose coupling for rinse water/cleaning agent
2 x 4/6 mm hose coupling for compressed air
2 x 4/6 mm hose coupling for pneumatic limit switches

Sensor protection in the process

integrated in immersion tube

Limit switches

noncontacting electrical limit-position control in conjunction with Uniclean® 900/Unical® 9000/
ZU 0631 or pneumatic limit switches for free hose connection

Certificates

3.1 Material Certificate (optional)
ATEX II 1 GD c II

*) Special connections on request



Product Line

Order No.

Process sensor lock-gate, pneumatic		WA 130 /	<input type="checkbox"/>	<input type="checkbox"/>	<input type="checkbox"/>	<input type="checkbox"/>	<input type="checkbox"/>	<input type="checkbox"/>	<input type="checkbox"/>	<input type="checkbox"/>	<input type="checkbox"/>	<input type="checkbox"/>	<input type="checkbox"/>	<input type="checkbox"/>	<input type="checkbox"/>	<input type="checkbox"/>	<input type="checkbox"/>	<input type="checkbox"/>	<input type="checkbox"/>	<input type="checkbox"/>
Explosion protection	for hazardous area Zone 1 without		X																	
Sensor	solid electrolyte liquid electrolyte (pressurization possible)		0	1																
Gasket material	elastomeric ring set A, FKM (Viton) elastomeric ring set B, EPDM elastomeric ring set C, FFKM (Kalrez) elastomeric ring set E, EPDM FDA elastomeric ring set K, FFKM, compl. (Kalrez)		A	B	C	E	K													
Process-wetted materials*)	1.4571/1.4571/1.4571 Hastelloy/Hastelloy/Hastelloy		A	B																
	PEEK/PEEK/PEEK PVDF/PVDF/PVDF		C	D																
	PEEK HD/PEEK HD/PEEK HD PVDF HD/PVDF HD/PVDF HD		E	F																
	Hastelloy/PEEK/Hastelloy Hastelloy/1.4571/PEEK		M	N																
	1.4571/1.4571/PEEK PP-H		Z	P																
Process adaptation	flange, steel 1.4571, DN 32 flange, steel 1.4571, DN 50 flange, steel 1.4571, DN 65 flange, steel 1.4571, DN 80 ¹⁾ flange, steel 1.4571, DN 100 ¹⁾		B 0	B 1	B 2	B 3	B 4													
	dairy pipe, DN 50 dairy pipe, DN 65 dairy pipe, DN 80 dairy pipe, DN 100		C 1	C 2	C 3	C 4														
	flange, ANSI 316, 1 1/2" flange, ANSI 316, 2" flange, ANSI 316, 2 1/2" flange, ANSI 316, 3" ¹⁾		D 0	D 1	D 2	D 3														
	Ingold socket, 25 mm (G 1 1/4") G 2 1/4" for ARF 210/30xxxx		H 0	K 1	A															
Immersion depth	short long				A	B														
Connection	media connection, PP media connection, PEEK media connection, PEEK, with integr. connection of add. medium				A	B	C													
Special variant	without equipped with special grease (provided by customer) with scraper ring, reinforced version, PTFE/PEEK (ZU 0760)											0 0 0	0 0 1	0 0 3						

*) Material combinations: Process-wetted part of calibration chamber/rinse-wetted part of calibration chamber/immersion tube

¹⁾ With the lower calibration chamber made of plastic, you require one of the following flange protectors: ZU 0755, ZU 0756, ZU 0757, ZU 0758

Pneumatic Retractable Fittings

Chem

Energy

Pharm

Food

Water

SensoGate® WA 130 for process applications

Accessories (Details from page 270)

Order No.

Service set	basic equipment	ZU 0680
	maintenance, repair, retrofit	ZU 0740
	calibration chamber	ZU 0754
Mounting aid	for 20 x 2.5 O-rings	ZU 0747
	for scraper ring	ZU 0746
Bellows	version for liquid-electrolyte sensors	ZU 0739
Protective cap	version for sensors with polymeric electrolyte	ZU 0759
Scraper ring	reinforced version, PTFE/PEEK	ZU 0760
Adapter for free hose connection	PP/EPDM (incl. electric feedback)	ZU 0733
	PP/EPDM (without electric feedback)	ZU 0734
	PEEK/EPDM (incl. electric feedback)	ZU 0742
Material Certificate 3.1		ZU 0708
Air supply	for pressurized sensors, 0.5 ... 4 bars	ZU 0670/1
	for pressurized sensors, 1 ... 7 bars	ZU 0670/2
Hose	20 m (extension for ZU 0670)	ZU 0713
Flange protectors	PEEK/FFKM DN 80	ZU 0755
	PEEK/FFKM DN 100	ZU 0756
	PVDF/FFKM DN 80	ZU 0757
	PVDF/FFKM DN 100	ZU 0758
Safety weld-in socket, straight, 40 mm	for tank wall	ZU 0717
	for pipe, DN 50	ZU 0717/DN50
	for pipe, DN 65	ZU 0717/DN65
	for pipe, DN 80	ZU 0717/DN80
	for pipe, DN 100	ZU 0717/DN100
Safety weld-in socket, beveled 15°, 40 mm	for tank wall	ZU 0718
	for pipe, DN 50	ZU 0718/DN50
	for pipe, DN 65	ZU 0718/DN65
	for pipe, DN 80	ZU 0718/DN80
	for pipe, DN 100	ZU 0718/DN100

For up-to-date information, please visit www.knick.com.br

Isolation Amplifiers
Transmitters

Indicators

Process Analytics

Portable Meters

Laboratory Meters

Sensors

Fittings

Knick 

Gaskets

	Set	Contact (process/rinse medium)	Order No.
Flange or dairy pipe	A/1	FKM	ZU 0689/1
	A/2	FKM/FKM	ZU 0689/2
	B/1	EPDM	ZU 0690/1
	B/2	EPDM/EPDM	ZU 0690/2
	C/1	FFKM	ZU 0691/1
	C/2	FFKM/FFKM	ZU 0691/2
	E/1	EPDM FDA	ZU 0692/1
	E/2	EPDM FDA/EPDM	ZU 0692/2
	K	FFKM/FFKM	ZU 0719
	Ingold socket	A/1	FKM
A/2		FKM/FKM	ZU 0693/2
B/1		EPDM	ZU 0694/1
B/2		EPDM/EPDM	ZU 0694/2
C/1		FFKM	ZU 0695/1
C/2		FFKM/FFKM	ZU 0695/2
E/1		EPDM FDA	ZU 0696/1
E/2		EPDM FDA/EPDM	ZU 0696/2
K		FFKM/FFKM	ZU 0720

Spare Parts

		Order No.
Immersion tube, short	1.4571	ZU 0722
	Hastelloy C22	ZU 0853
	PEEK	ZU 0724
	PVDF	ZU 0726
	PP	ZU 0825
Immersion tube, long	1.4571	ZU 0723
	Hastelloy C22	ZU 0854
	PEEK	ZU 0725
	PVDF	ZU 0727
	PP	ZU 0826

Pneumatic Retractable Fittings

Chem

Energy

Pharm

Food

Water

SensoGate® WA 130 for process applications

Dimension Drawings

Installation dimensions for SensoGate® WA 130 with short immersion depth for sensors with gel electrolyte

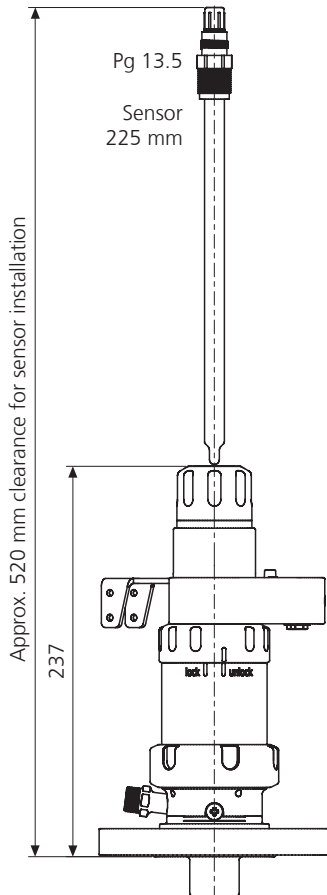

Installation dimensions for SensoGate® WA 130 with long immersion depth for sensors with gel electrolyte

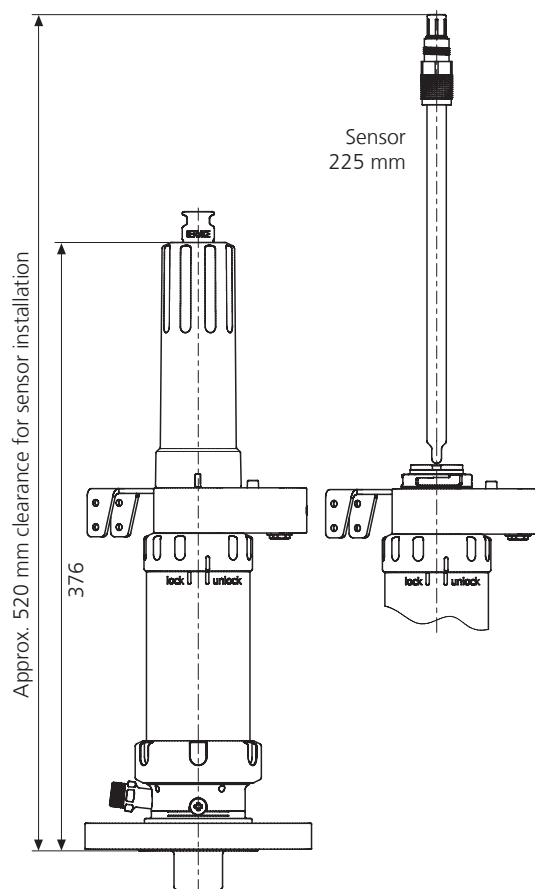

Installation dimensions for SensoGate® WA 130 for sensors with liquid electrolyte

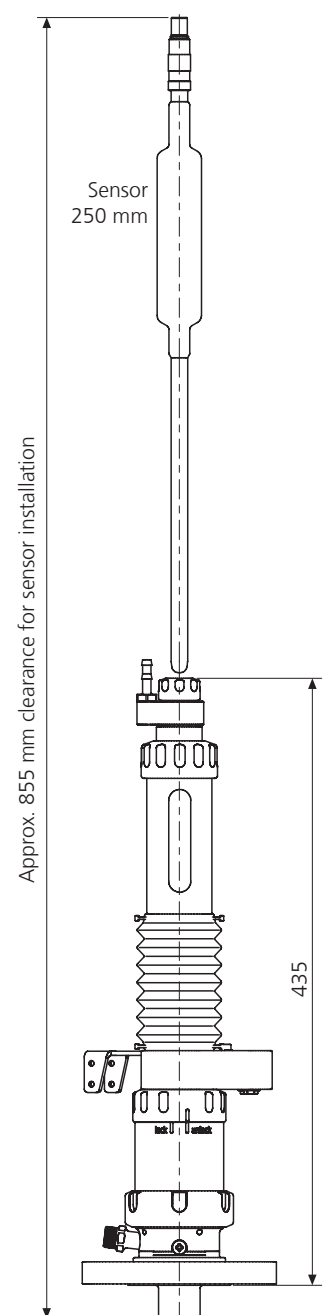

SensoGate® WA 130
Process adaptation for flange DN 32 ... 100
ANSI 316, 1 1/2" ... 3",
short and long
immersion depth

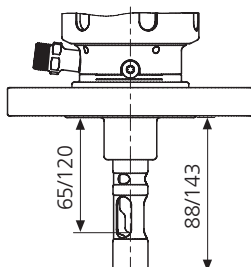

SensoGate® WA 130
Process adaptation for 25-mm Ingold socket,
short and long
immersion depth

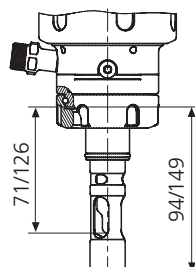

SensoGate® WA 130
Process adaptation for dairy pipe,
DIN 11851 DN 50 ... 100,
short and long
immersion depth

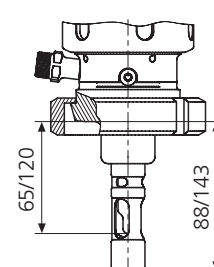

For up-to-date information, please visit www.knick.com.br

Isolation Amplifiers
Transmitters

Indicators

Process Analytics

Portable Meters

Laboratory Meters

Sensors

Fittings

Knick 