

Chem

Energy

Pharm

Food

Water



Ceramat® Sensor Lock-Gate

Automatic sensor lock-gate for extreme applications with ceramic sealing to the proces

Unique lock-gate principle

The usual O-ring seal problems occurring in conventional retractable fittings are eliminated. The O-rings are replaced by two superpolished planar ceramic disks which separate the calibration chamber from the process by a rotary movement.

The ceramic seal between calibration chamber and process is harder than steel and extremely resistant to chemical, thermal, and mechanical influences – a guarantor for highest availability and process safety.

The Ceramat® sensor lock-gate has proved particularly successful in extremely difficult processes where standard O-ring seals fail.

- Ceramic slide
- not moved
- movably supported
- contact pressure provided by Hastelloy springs

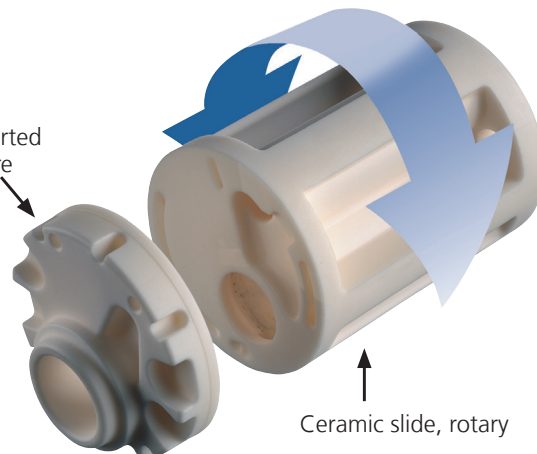

The process-wetted outer housing (PVDF, PEEK, or steel) always remains static and is therefore not subjected to mechanical stress. The unit is driven by a compact pneumatic rotary-lift motor with positively controlled, integrated valves.

Maintenance without process interruption

The particular ease of maintenance of the sensor lock-gate is achieved by a well thought-out design that allows the few maintenance operations required to be performed on site without the aid of a workshop.

A unique feature is the easy separation of the complete drive unit under full process conditions. That means that the process medium – which might be corrosive, hot, toxic, and under pressure – remains reliably sealed off. This also allows cleaning the calibration chamber under process conditions when the sensor is broken.

Easy replacement of the drive unit also under process pressure:

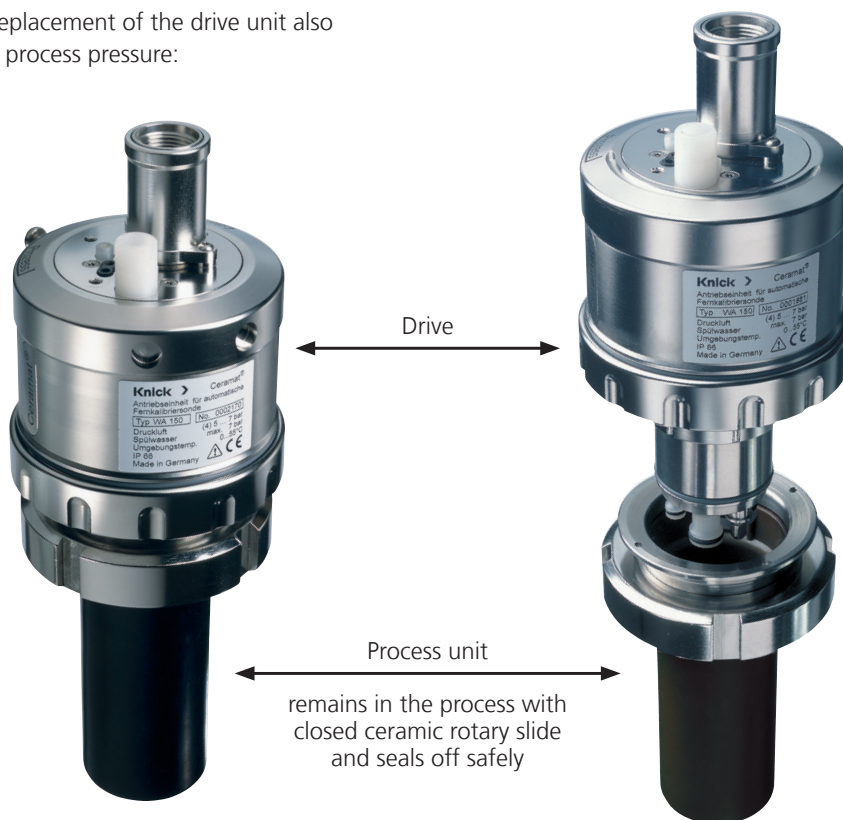

Pneumatic Retractable Fittings

Chem

Energy

Pharm

Food

Water

Ceramat® Sensor Lock-Gate

Effective Sensor Cleaning

A unique feature is the tangential routing of the rinse media with high flow rates for an optimum cleaning effect of the sensor.

Service position: for rinsing or filling of the calibration/cleaning chamber or for sensor removal (SIP and CIP compliant):

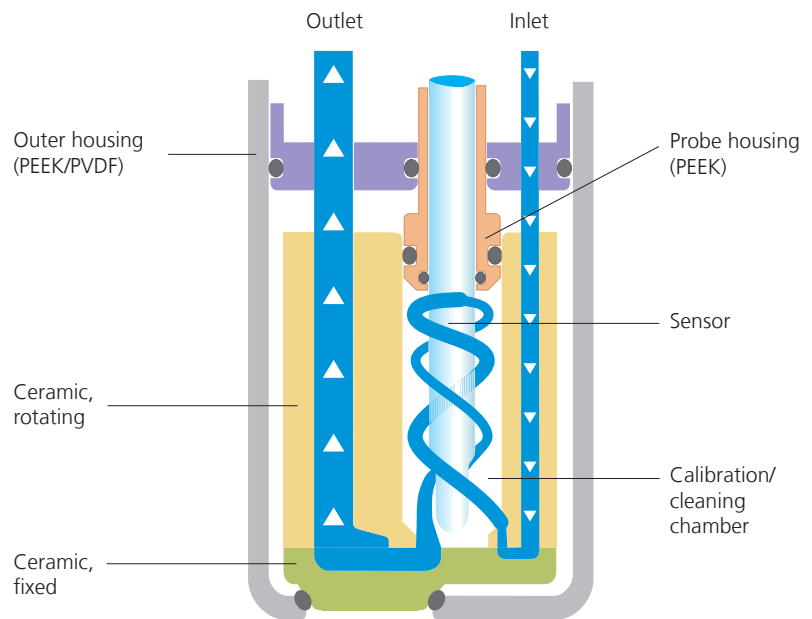

Cavity Rinsing

The Ceramat® sensor lock-gates provide an additional cavity rinsing between housing and ceramic elements, ensuring that no area is left unrinsed or uncleaned. They are particularly suitable for sensitive processes with high safety requirements.

The design meets the standards of the IGB (Fraunhofer Institute for Interfacial Engineering and Biotechnology) in Stuttgart.

Process position: Cavity rinsing (SIP and CIP compliant):

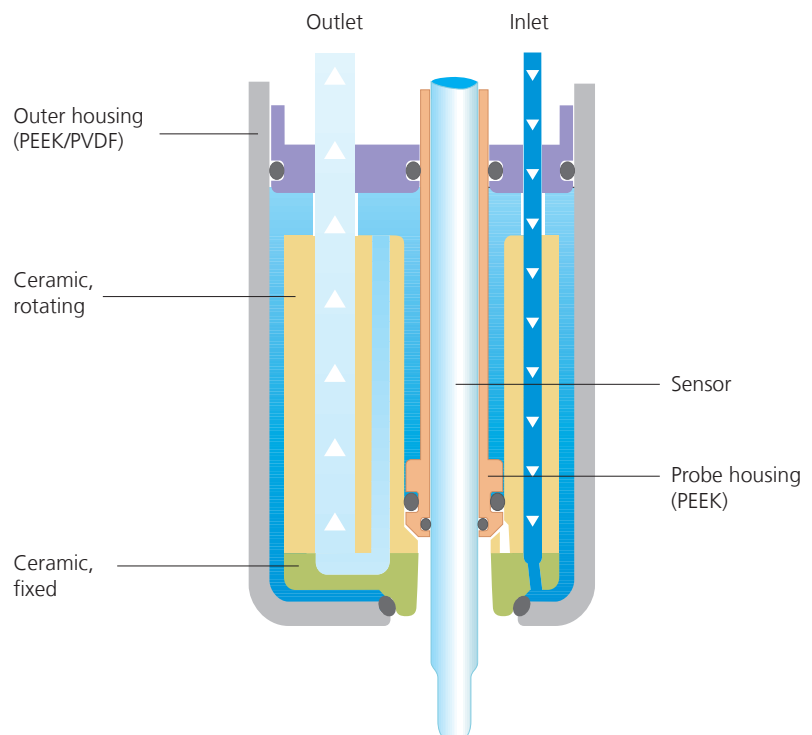

Position Indication

Clear indication of Ceramat® position:
service and process



Plug & Play

The central multiplug contains tubings for rinsing, cleaning, and calibration media, including check valves and limit switches and enables a fast, safe, and space-saving connection.



Applications

- Highly corrosive processes, e.g. chlorine production, phosgenation
- Processes with depositing, abrasive, and incrusting solids: flue gas desulfurization, gas scrubbers, sugar production (1st + 2nd carbonatation), dyes and pigment synthesis, special incrusting industrial wastewaters
- Pulpy, fibrous media (cellulose, cosmetics, food)
- Organic and sticky residues: refinery wash waters, starch production

Pneumatic Retractable Fittings

Chem

Energy

Pharm

Food

Water

Ceramat® WA 150

Inline version with application-specific process adaptation

Facts

- for extreme applications
- ceramic sealing to the process:
 - extremely high hardness (Mohs hardness 9) prevents wear on the sealing surfaces in abrasive media
 - virtually wear-resistant
 - high and constant tightness due to lapped and polished sealing surfaces
 - high mechanical strength
 - high temperature resistance
 - high chemical resistance
 - sterilizable
- very high availability
- Plug & Play for all process media thanks to central multiplug
- smooth, dirt-proof design
- all maintenance can be performed on site
- drive easily replaceable under process conditions
- cyclone rinsing for optimum cleaning effect
- 2 independent barriers with cavity rinsing
- sensor dismount guard in conjunction with Uniclean® 900/Unical® 9000
- superior sensor immersion depth
- standard sensor length (225 mm)
- special version for electrodes with pressurizable liquid electrolyte (for 250-mm electrodes with electrolyte reservoir)
- process-wetted outer body, PVDF or PEEK, carbon-fiber reinforced

Immersion Depth

Comparably deep immersion depth, yet with very compact design:

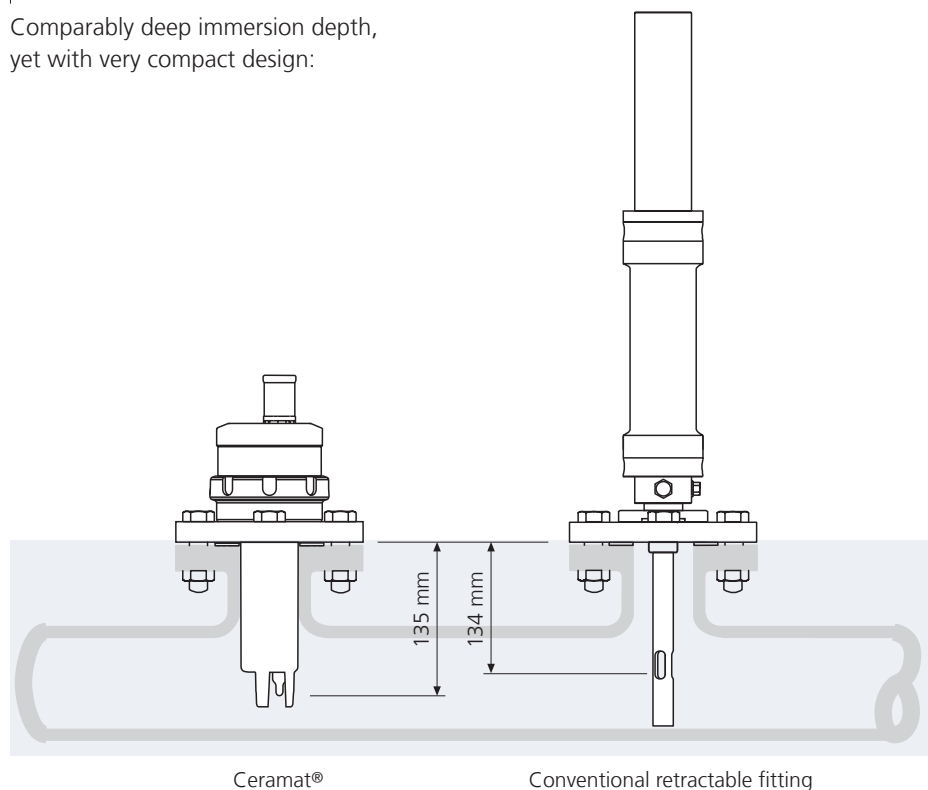



Product Line

Order No.

Basic unit		WA 150 /	<input type="checkbox"/>	<input type="checkbox"/>	<input type="checkbox"/>	<input type="checkbox"/>	<input type="checkbox"/>	<input type="checkbox"/>	<input type="checkbox"/>	<input type="checkbox"/>	<input type="checkbox"/>	<input type="checkbox"/>	<input type="checkbox"/>	<input type="checkbox"/>
Explosion protection	for hazardous area Zone 0 without	X N												
Sensor	solid electrolyte liquid electrolyte (pressurization possible)	0 1												
Gasket material (see table on page 286)	Set A FKM (Viton) Set B EPDM Set C FFKM (Kalrez) Set E (EPDM FDA)	A B C E												
Material of probe housing and sensor socket	PEEK with integrated sensor protection	A												
	PVDF with integrated sensor protection	B												
	PEEK without integrated sensor protection	C												
	PVDF without integrated sensor protection	D												
	PEEK, sensor socket, long, 1.4571, without integr. sensor protection	H												
	PEEK, sensor socket, long, C22, without integr. sensor protection	J												
	PVDF, sensor socket, long, 1.4571, without integr. sensor protection	K												
	PVDF, sensor socket, long, C22, without integr. sensor protection	L												
	PEEK, without sensor protection (socket with scraper ring)	M												
	PEEK, sensor socket, full sensor protection, 1.4571, without integrated sensor protection	N												
PVDF, sensor socket, full sensor protection, 1.4571, without integrated sensor protection	O													
PEEK, sensor socket, full sensor protection, C22, without integrated sensor protection	P													
PVDF, sensor socket, full sensor protection, C22, without integrated sensor protection	Q													
Process adaptation	steel flange, 1.4571, DN 50, fixed	A 1												
	flange, 1.4571 steel, DN 50, loose	B 1												
	flange, 1.4571 steel, DN 65, loose	B 2												
	flange, 1.4571 steel, DN 80, loose	B 3												
	(flange protector DN 80 required)													
	flange, 1.4571 steel, DN 100, loose	B 4												
	(flange protector DN 100 required)													
	dairy pipe DN 50	C 1												
	dairy pipe DN 65	C 2												
	dairy pipe DN 80	C 3												
	dairy pipe DN 100	C 4												
	flange: ANSI 316, 2 inches, Class 150	D 1												
	flange: ANSI 316, 3 inches, Class 150	D 3												
flange, 1.4571 steel, DN 65, loose, EPDM pneumatic deposit remover	F 2													
flange, 1.4571 steel, DN 80, loose, EPDM pneumatic deposit remover	F 3													
flange, 1.4571 steel, DN 65, loose, FKM pneumatic deposit remover	G 2													
flange, 1.4571 steel, DN 80, loose, FKM pneumatic deposit remover	G 3													
Varivent DN 50 ... 125	V 1													
Special version	none											0	0	0

Pneumatic Retractable Fittings

Chem

Energy

Pharm

Food

Water

Ceramat® WA 150

Specifications

Permitted process temp

5 ... 120 °C, for sterilization 130 ... 140 °C

Permitted process pressure

6 bars gauge pressure at 120 °C

Sensors

225 mm, Pg 13.5 coupling,
250 mm for pressurized liquid-electrolyte sensors

Air supply

(4) 5*) ... 7 bars, filtered 10 ... 25 µm, oil- and condensate-free

Immersion depth

approx. 135 mm, measured from lower edge of flange to sensor tip

Process adaptations

flanges: DN 50/DN 65/DN 80/DN 100
flange, DN 65/80, EPDM pneumatic deposit remover (see page 285)
dairy-pipe screw joint DN 50/DN 65/DN 80/DN 100
Varivent DN 50 ... 125 mm

Outlet

connection for hose grommet with coupling (Unical® 9000/Uniclean® 900)
internal shut-off by ceramic disks

Inlet

multiplug connection for Unical®/Uniclean®
internal shut-off by ceramic disks

Special functions

rinsing of inner cavities

Process-wetted materials

PEEK, carbon-fiber reinforced, or PVDF, carbon-fiber reinforced; ceramic (aluminum oxide);
O-rings made of EPDM, FKM, or FFKM

Enclosure

stainless steel 1.4571

Tightness

IP 66

Connection to Uniclean® 900/
Unical® 9000

compact multiplug connection

Sensor protection in the
process

integrated sensor protection made of PVDF (carbon-fiber reinforced) or
PEEK (carbon-fiber reinforced)

Limit switches

noncontacting electrical limit position control in conjunction with Unical® 9000/Uniclean® 900
or ZU 0631 Standard Media Interface

Certificates

3.1 Material Certificate (optional)
ATEX II 1 GD c II

*) with sticky media containing particles

For up-to-date information, please visit www.knick.com.br

Isolation Amplifiers
Transmitters

Indicators

Process Analytics

Portable Meters

Laboratory Meters

Sensors

Fittings

Knick >

Typical Variants

Sensor with solid electrolyte, 225 mm



Sensor with liquid electrolyte, pressurizable, 250 mm



Pneumatic Retractable Fittings

Chem

Energy

Pharm

Food

Water

Ceramat® WA 150

Dimension Drawings

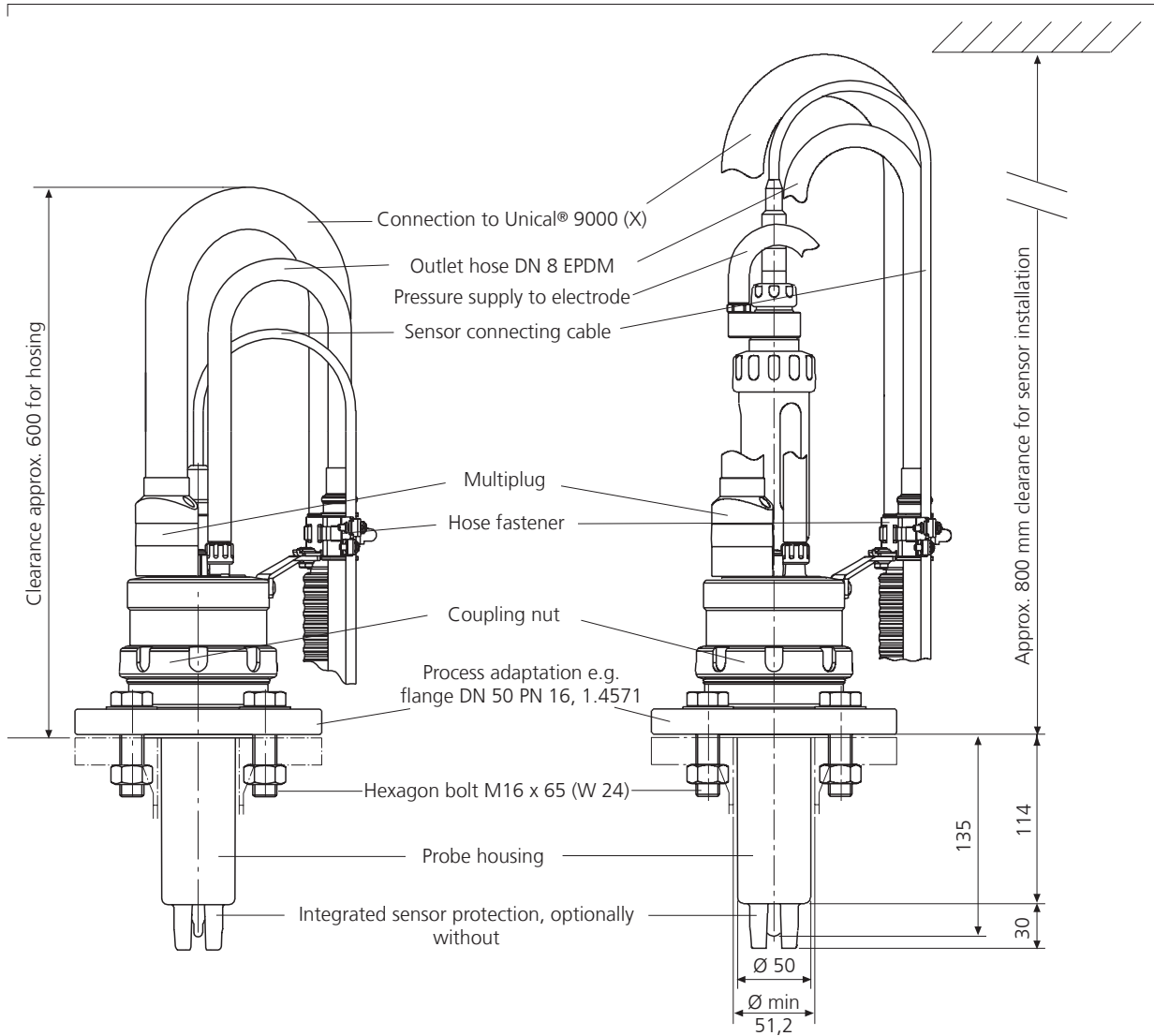

Varivent process adaptation

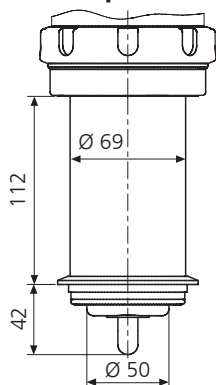

Dairy-pipe process adaptation

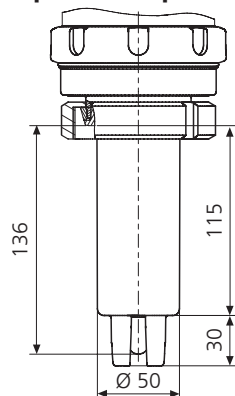

Typical Variants of Process Adaptation

Flange process adaptation

DN 50 ... DN 100



Flange process adaptation with pneumatic deposit remover

for removing brittle incrustations (e.g. lime) without interrupting the process.

Function principle: pneumatically moved elastomeric bellows



Specifications

Air connection (drive)

hose grommet DN 6

Pressure-relief valve

factory-set according to process pressure

Recommended accessories

pressure reducer with ZU 0670 pressure gauge, ZU 0672 or ZU 0673 sensor socket, long

Operation with Unical® 9000/ Uniclean® 900

"Supplementary ext. valve control kit" required (see page 312)

Process-wetted materials

EPDM or FKM

Process connection

DN 65 or DN 80 flansch

Dairy-pipe process adaptation

DN 50 ... DN 100



Varivent process adaptation

DN 50



Pneumatic Retractable Fittings

Chem

Energy

Pharm

Food

Water

Ceramat® WA 150

Accessories for Ceramat® WA 150 (Details from page 298)

Order No.

Sensor mounting wrench, 19 mm	ZU 0647
Ceramat® mounting wrench	ZU 0648
Standard media (SM) interface	ZU 0631
Pneumatically operated manual control valve	ZU 0646
Pneumatically controlled 3/8" valve for additional medium	ZU 0669
Adapter for additional medium, PEEK/FKM	ZU 0654/1
Adapter for additional medium, PEEK/EPDM	ZU 0654/2
Adapter for additional medium, PEEK/FFKM	ZU 0654/3
Adapter for additional medium, steel 1.4571/FKM	ZU 0655/1
Adapter for additional medium, steel 1.4571/EPDM	ZU 0655/2
Adapter for additional medium, steel 1.4571/FFKM	ZU 0655/3
Flange protector DN 80, PEEK	ZU 0595
Flange protector DN 80, PVDF	ZU 0596
Flange protector DN 100, PEEK	ZU 0597
Flange protector DN 100, PVDF	ZU 0598
Air supply for pressurized sensors, 0.5 ... 4 bars	ZU 0670/1
Air supply for pressurized sensors, 1 ... 7 bars	ZU 0670/2
Hose, 20 m (extension for ZU 0670)	ZU 0713

Gaskets for Ceramat® WA 150

Order No.

Gaskets	Set	process-wetted material	
Flange or dairy pipe	A	FKM	ZU 0624
	B	EPDM	ZU 0625
	C	FFKM	ZU 0626
	E	EPDM FDA	ZU 0661

For up-to-date information, please visit www.knick.com.br

Isolation Amplifiers
Transmitters

Indicators

Process Analytics

Portable Meters

Laboratory Meters

Sensors

Fittings

Knick 

Sensor Sockets for Ceramat® WA 150 (Details from page 303)

Order No.

Sensor socket PEEK/FKM	ZU 0616
Sensor socket PEEK/EPDM	ZU 0617
Sensor socket PEEK/FFKM	ZU 0618
Sensor socket PEEK/EPDM FDA	ZU 0619
Sensor socket PEEK/FKM (with scraper ring)	ZU 0705
Sensor socket PEEK/EPDM (with scraper ring)	ZU 0706
Sensor socket PEEK/FFKM (with scraper ring)	ZU 0707
Sensor socket PVDF/FKM	ZU 0620
Sensor socket PVDF/EPDM	ZU 0621
Sensor socket PVDF/FFKM	ZU 0622
Sensor socket PVDF/EPDM FDA	ZU 0623
Sensor socket, long, 1.4571/FKM	ZU 0672/A
Sensor socket, long, 1.4571/EPDM	ZU 0672/B
Sensor socket, long, 1.4571/FFKM	ZU 0672/C
Sensor socket, long, Hastelloy/FKM	ZU 0673/A
Sensor socket, long, Hastelloy/EPDM	ZU 0673/B
Sensor socket, long, Hastelloy/FFKM	ZU 0673/C
Sensor socket full sensor protection, Hastelloy C22/FKM	ZU 0808/A
Sensor socket full sensor protection, Hastelloy C22/EPDM	ZU 0808/B
Sensor socket full sensor protection, Hastelloy C22/FFKM	ZU 0808/C
Sensor socket full sensor protection/FKM	ZU 0820/A
Sensor socket full sensor protection/EPDM	ZU 0820/B
Sensor socket full sensor protection/FFKM	ZU 0820/C